

Yakovlev Yak 40

Plastic model

scale :1/72

The Yakovlev Yak-40 (NATO reporting name: Codling) is a small, three-engined airliner that is often called the first regional jet transport aircraft. It was introduced in September 1968 with Aeroflot. The first of five prototypes (SSSR-1966) was first flown on 21 October 1966 by Yakovlev test pilots A I Kolossov and Yu B Petrov. Passenger service began on 30 September 1968. By the time production ended in 1981 the factory at Saratov had produced 1,011 aircraft. A total of 130 aircraft were exported to Afghanistan, Angola, Bulgaria, Cambodia, Cuba, Czechoslovakia, Equatorial Guinea, Ethiopia, Germany, Hungary, Italy, Laos, Madagascar, Poland, Syria, Vietnam, Yugoslavia and Zambia.

Plastic parts

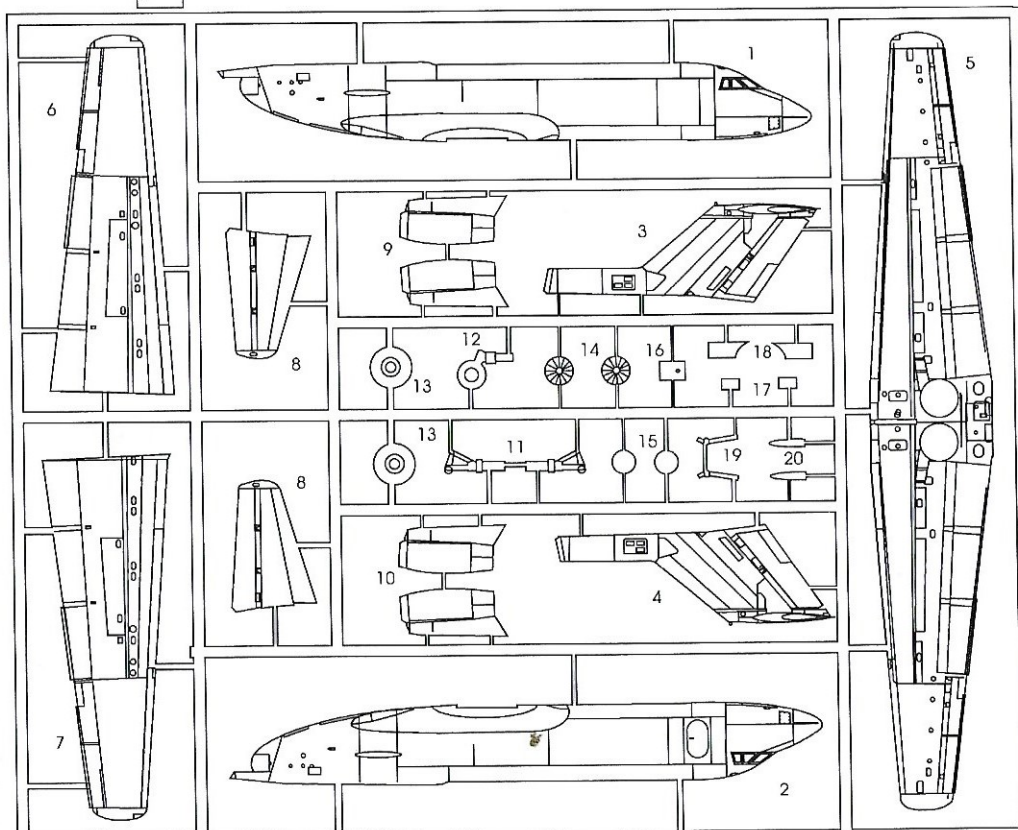

	Colour name	Number	Colour name	Number
A	Black		F	
B	White		G	
C	Light Grey		H	
D	Steel			
E	Aluminium			

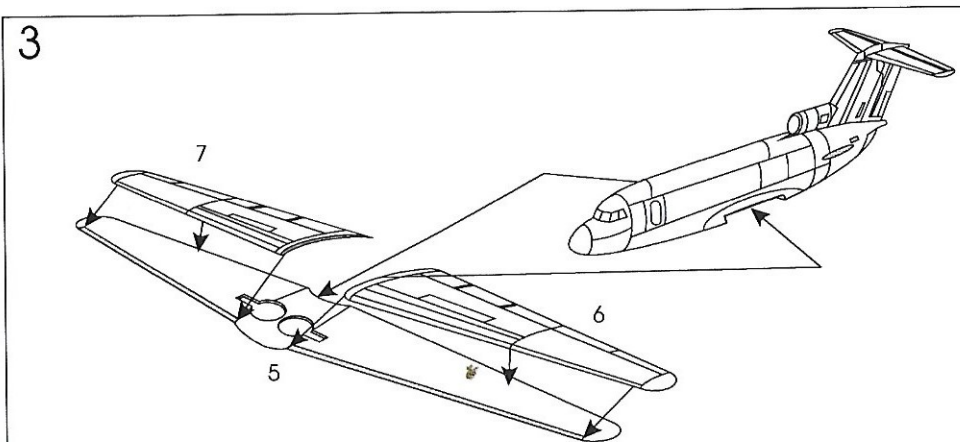
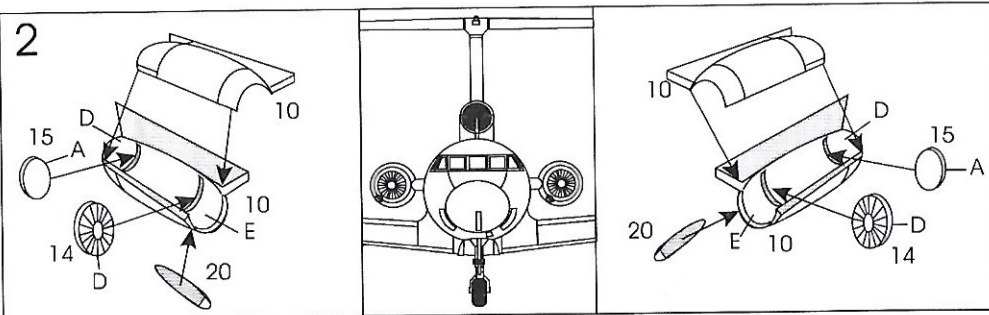
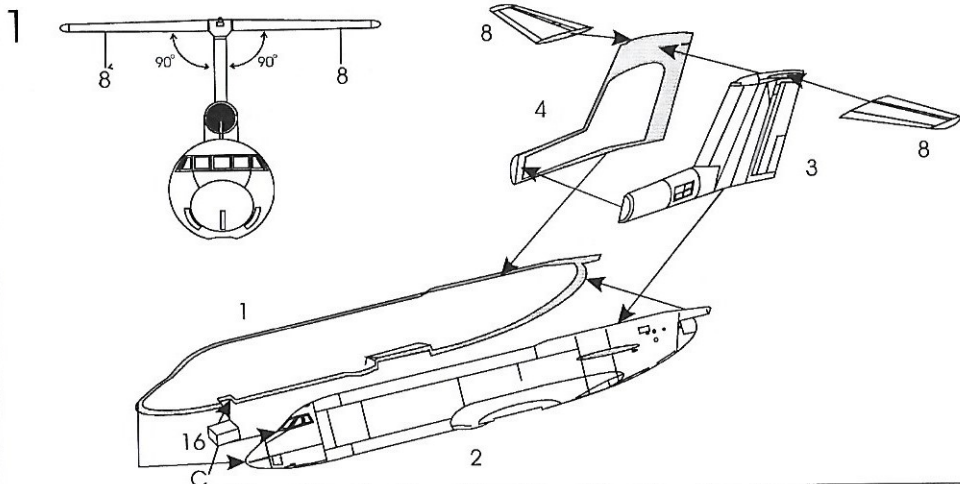

4

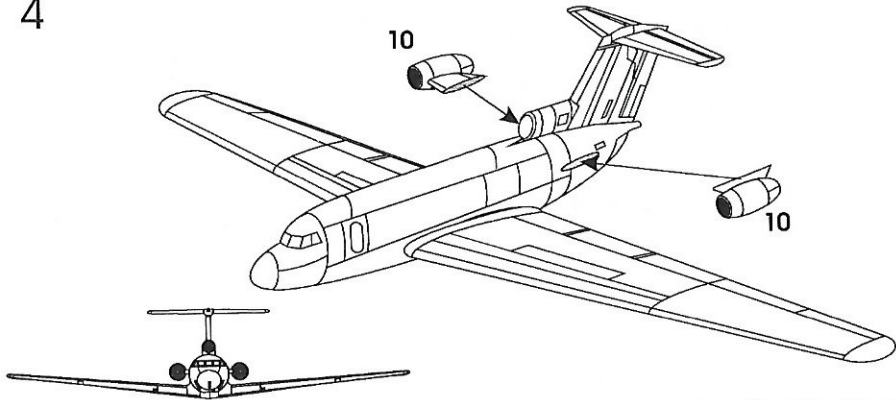

5

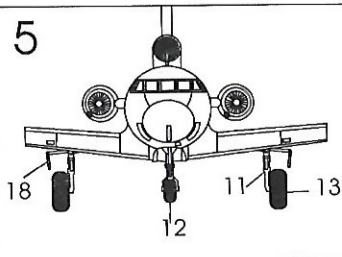

8

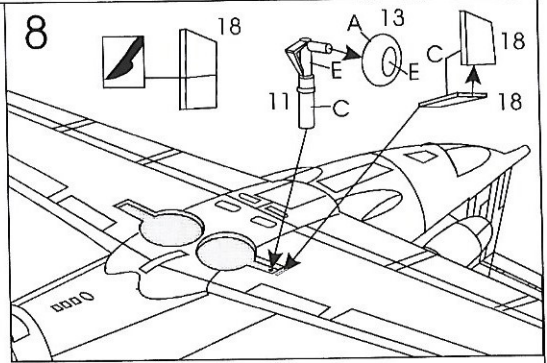

6

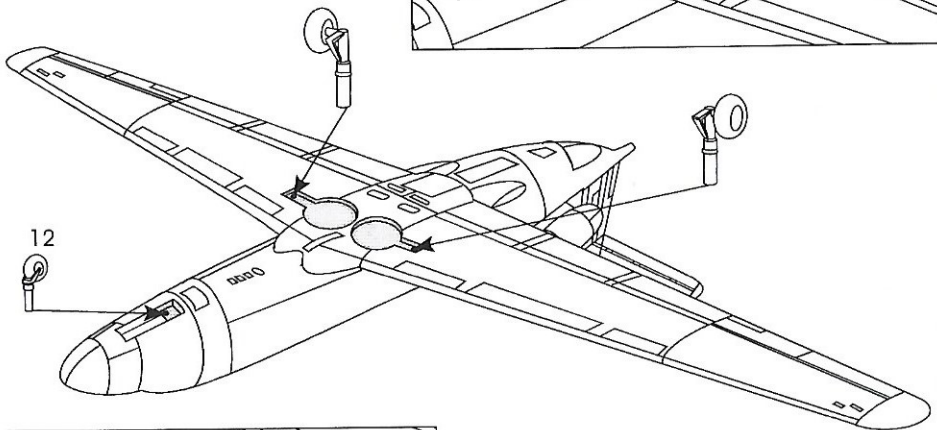

7

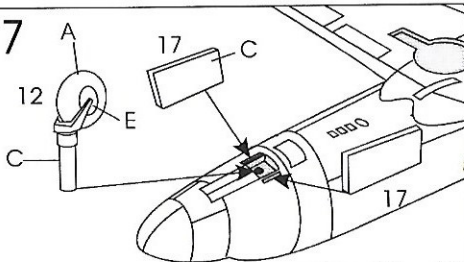

Yakovlev Yak 40

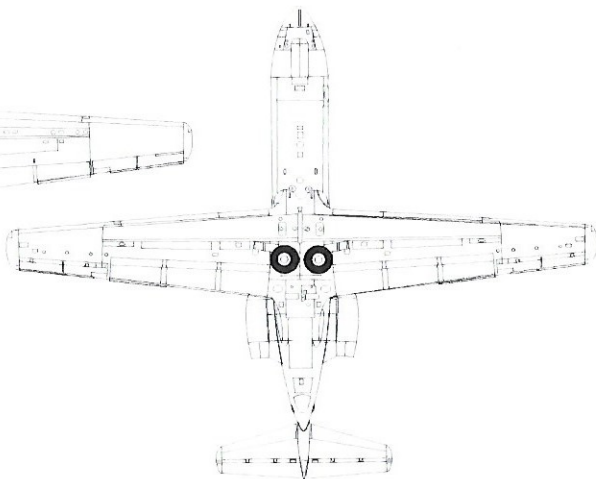
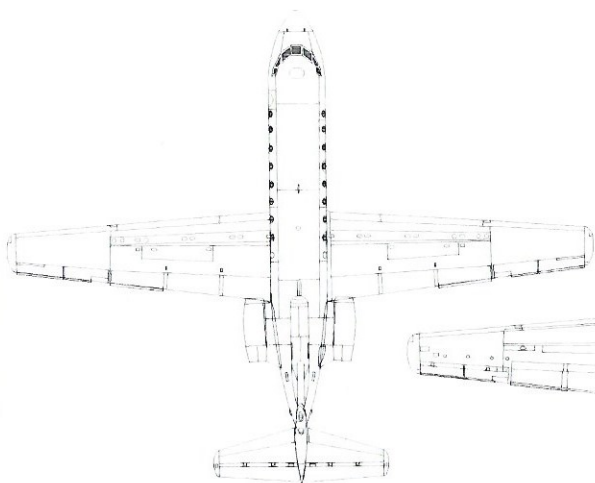
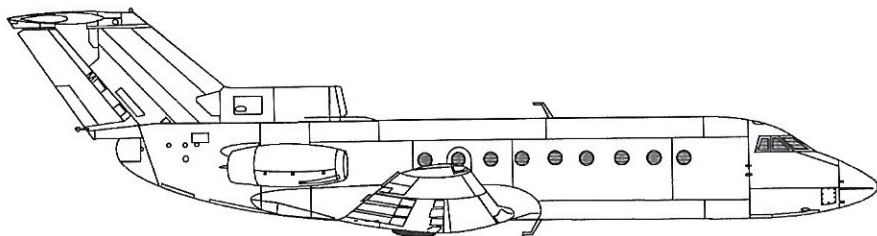
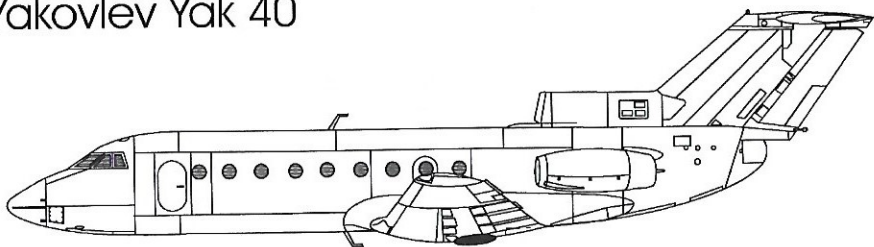

1 Yak-40, CSA, Czechoslovak Airlines

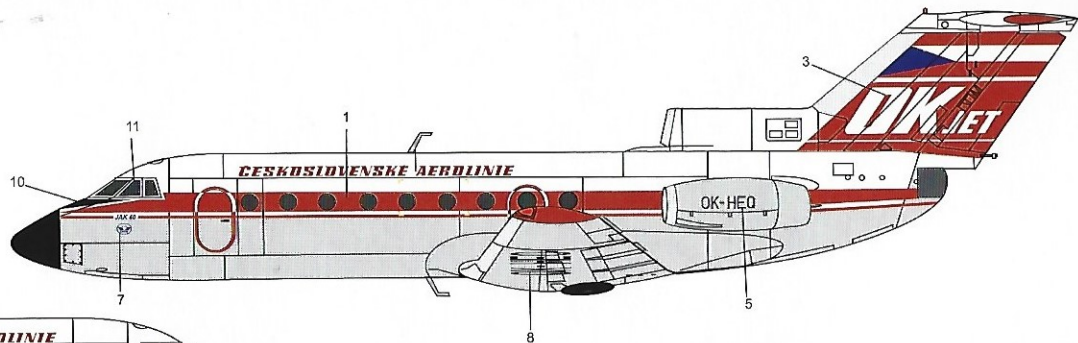
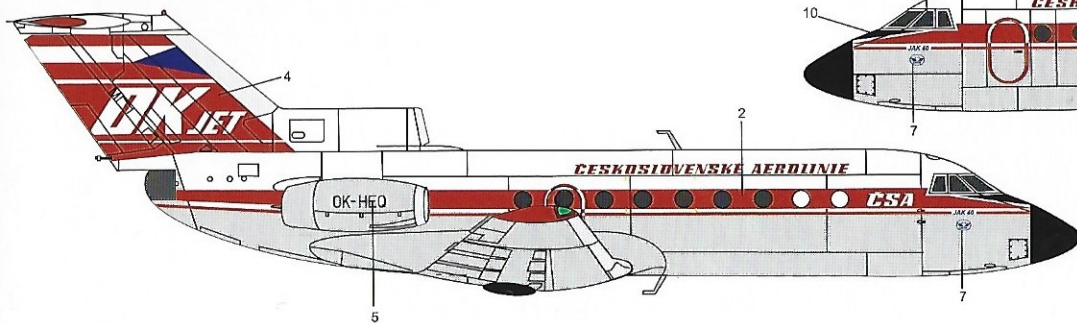

2 Yak-40, General Air, West Germany

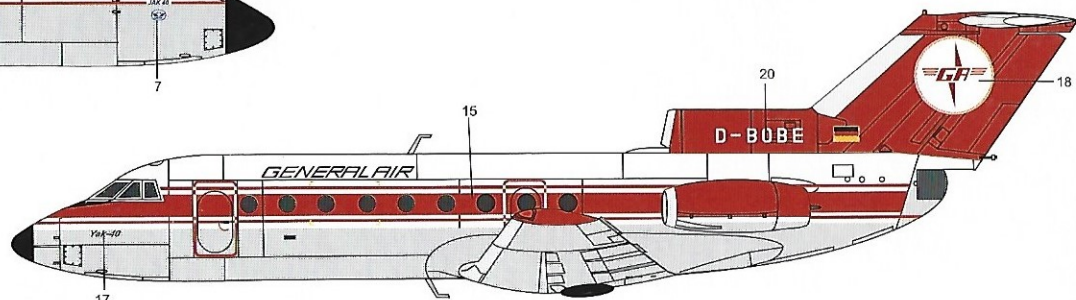
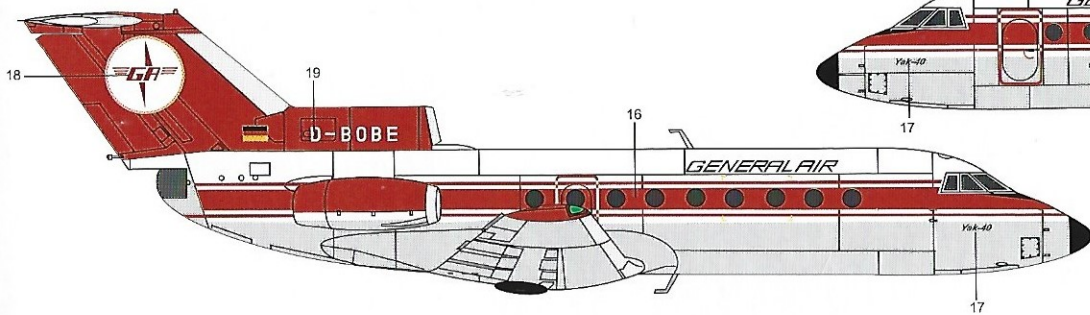

1

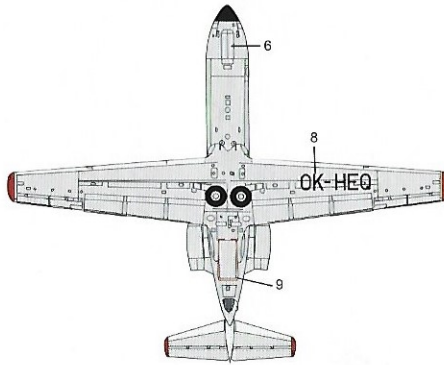
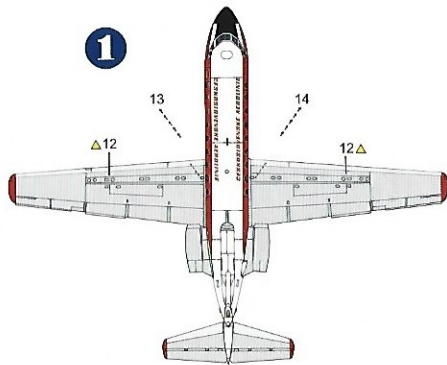

2

