

BELL 47J / HUL-1

KIT NO. PE4901

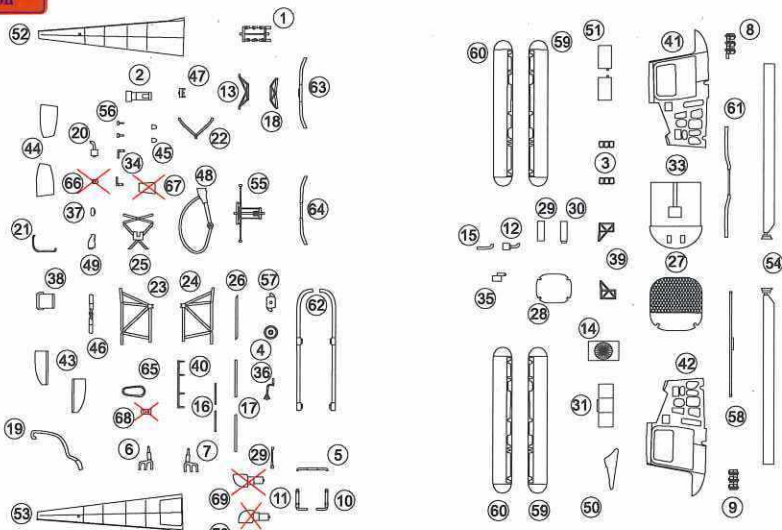

Kabina
Canopy

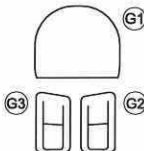

Leptané díly
Photo-etched parts

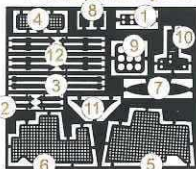

Obtisky / decals



Palubní deska
Instrument panel



Barvy / Colours
[AK Real Colors]

- | | | |
|------------------------|-------------------------|-------------------------|
| A White / RC004 | C Red / RC005 | E Black / RC001 |
| B Blue / RC010 | D Yellow / RC007 | F Orange / RC009 |

Bell 47J Ranger je americký jednomotorový lehký vrtulník s jedním motorem, který vyráběla firma Bell Helicopter. Byla to výkonná varianta velmi úspěšného vrtulníku Bell 47 a byl to první vrtulník, který nesl prezidenta Spojených Států (1). První vrtulník této nové série obdržel registraci N2478B a byl dokončen 1. listopadu 1955. Od roku 1957 byl Ranger vyráběn v Itálii na základě licence "Costruzioni Aeronautiche Giovanni Agusta". Agusta také vyrobila tři dílčí varianty známé jako J-3, J-3B a J-3B-1 (2).

Specifikace:

Délka: 9,87m; Průměr rotoru: 11,33m; Výška : 2,83m; Dolet: 415km; Dostup: 3400m.

The Bell 47J Ranger is an American single-engine single-rotor light helicopter manufactured by Bell Helicopter. It was an executive variant of the highly successful Bell 47 and was the first helicopter to carry an United States president (1). The first helicopter of this new series received registration N2478B and was completed on November 1, 1955. Since 1957 the 47J Ranger was built under license in Italy by "Costruzioni Aeronautiche Giovanni Agusta". Agusta also manufactured three sub-variants known as a J-3, J3B nad J3B-1 (2).

Specification:

Length: 9,87 m; Main rotor diameter: 11,33 m; Height: 2,83 m; Range: 415 km; Service ceiling: 3 400 m.

- (1) Bell 47J Ranger, on-line source - https://en.wikipedia.org/wiki/Bell_47J_Ranger
 (2) The Bell 47J Ranger story-heli-archive.ch - <https://www.heli-archive.ch/en/helicopters/in-depth-articles/bell-47j-ranger/>

A.

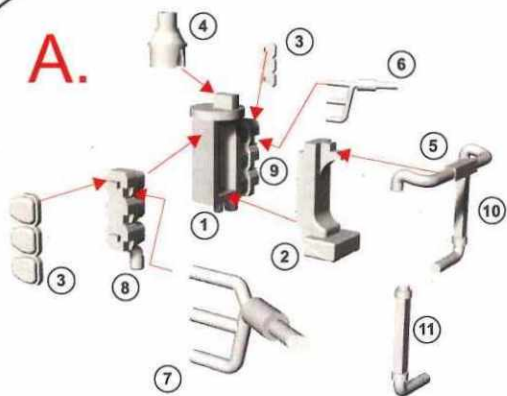

B.

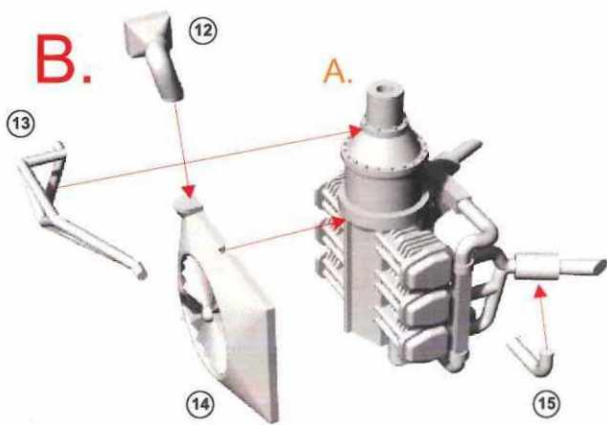

C.

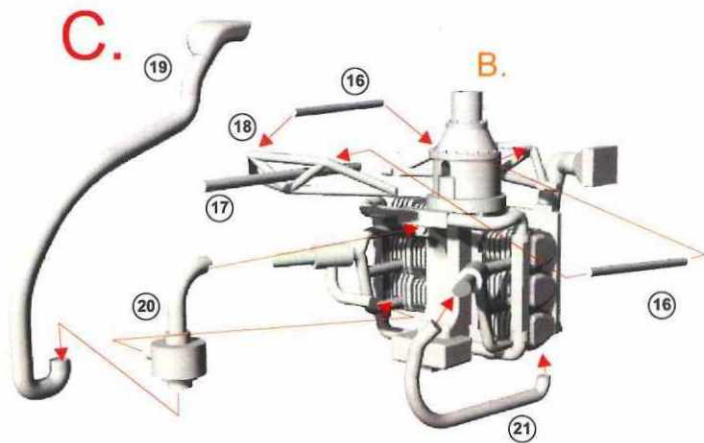

D.

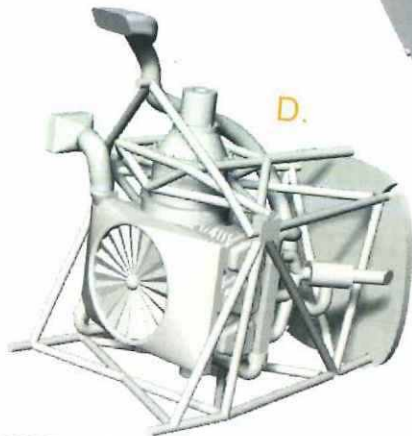
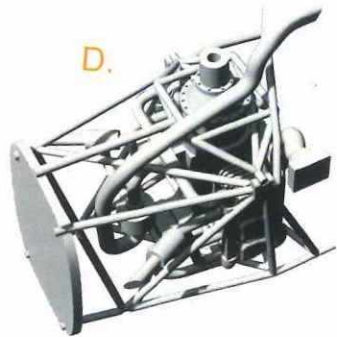
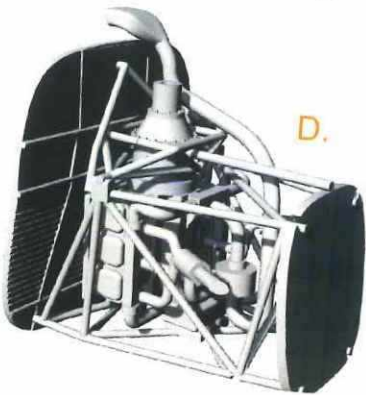
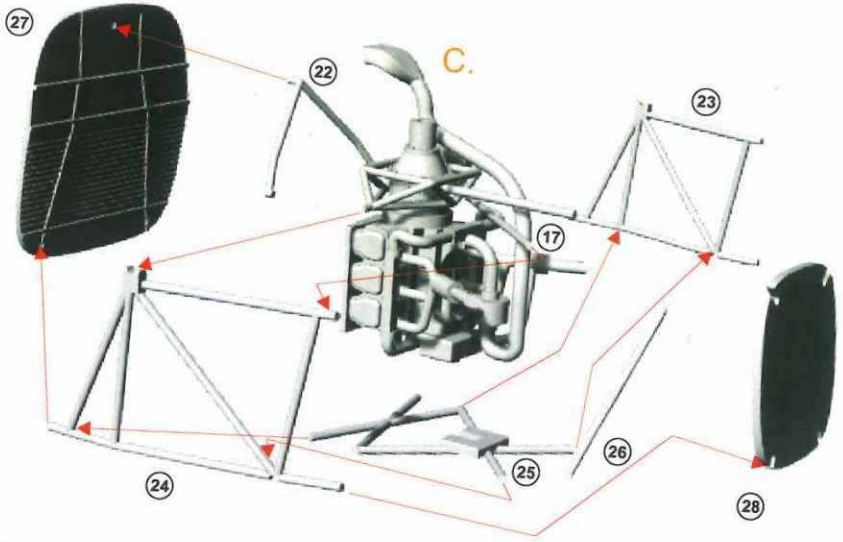

E.

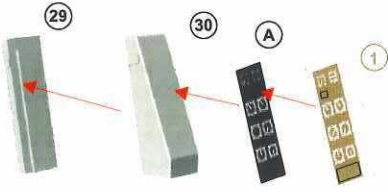

F.

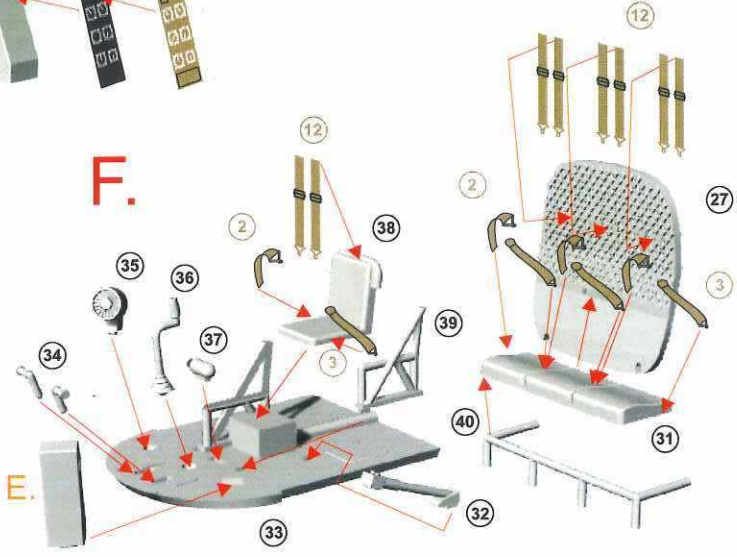

G.

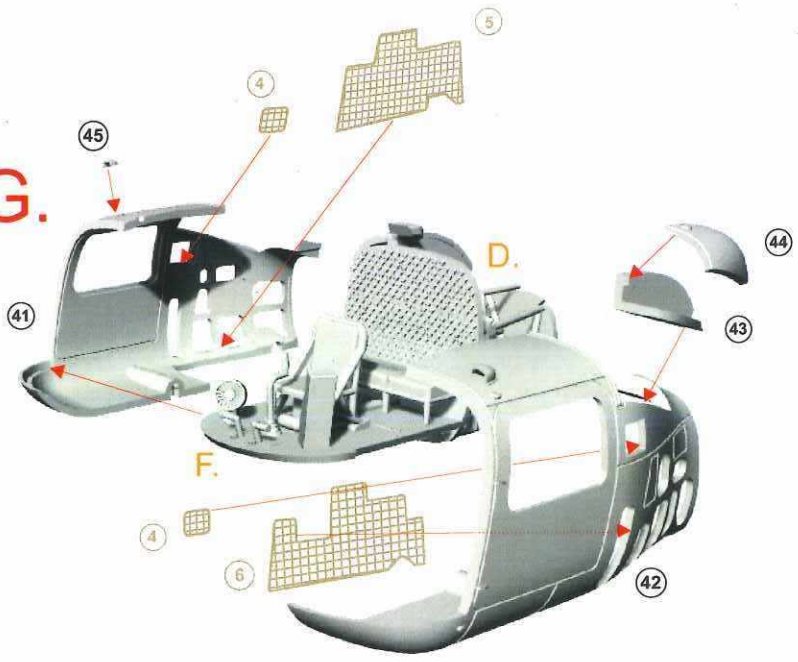

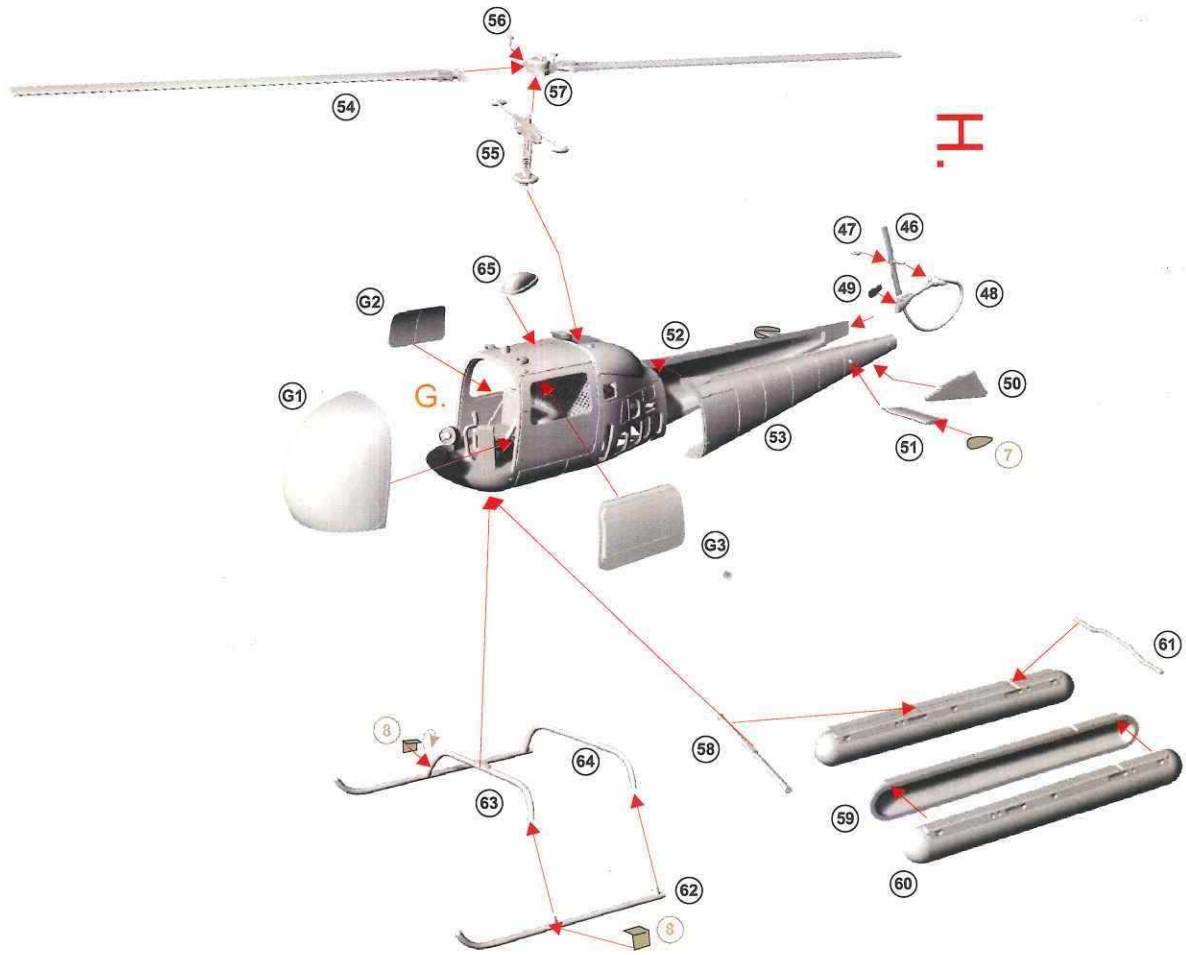

Painting and marking

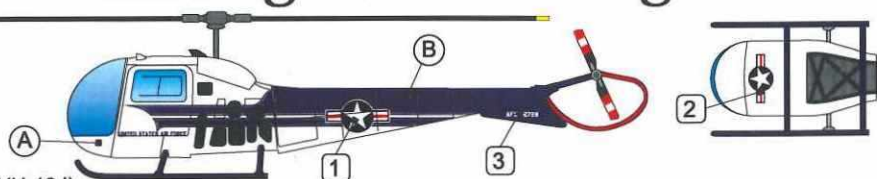

1. Bell 47J-1(H-13J)
acquired by the U.S. Air Force
for VIP transport
of the U.S. President.

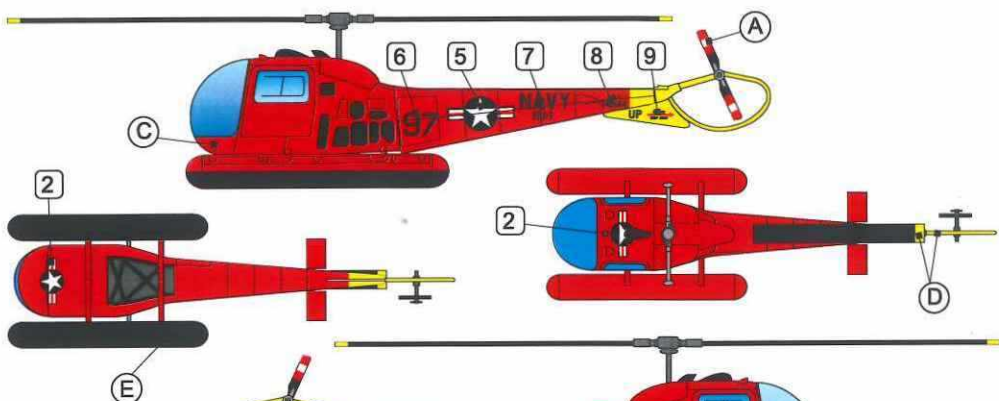

2. Bell HUL-1
US NAVY, Helicopter Utility Squadron
1955-1956

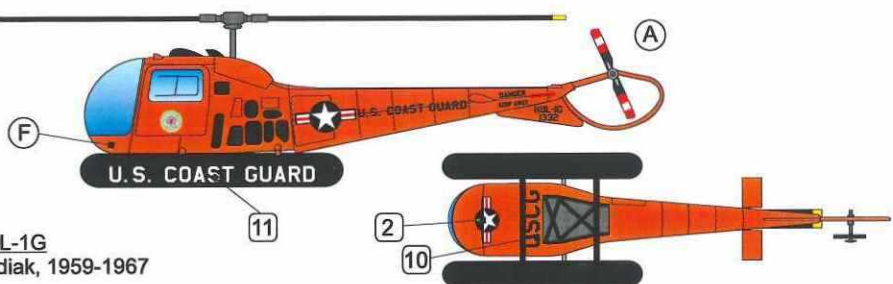

3. Bell HUL-1G
CGAS Kodiak, 1959-1967

