

# ANBO - II

RSSH - 72002

**HBBIS**  
Scale Scratchbuilt Hobby

Thanks for your interest in this model.

**ANBO-II** was the second aircraft of the Lithuanian aircraft designer **Antanas Gustaitis**.

**ANBO-II** - light multipurpose aircraft. It was operated from 1927 to 1931 as a training aircraft for young military pilots. In 1931, after major repairs and changes, it was transferred to the Aero Club of Lithuania. The plane crashed and was written off in 1934.

The plane was not produced in series, yet it served as a prototype for latter trainers ANBO-III and ANBO-V/51, developed by Antanas Gustaitis.

**Crew:** two

**Length:** 6.75 m

**Wingspan:** 10.72 m

**Wing area:** 20 m<sup>2</sup>

**Empty weight:** 280 kg

**Gross weight:** 550 kg

**Powerplant:** 1 × Walter NZ 60, 45 kW (60 hp)

**Maximum speed:** 160 km/h

**Service ceiling:** 3,500 m

**Rate of climb:** 2.1 m/s

A full size flying replica was restored in 2012-2016 and mostly used for air shows. Unfortunately the plane crashed in 2021.

The model is identical to ANBO-II during the period of operation 1925-1931.

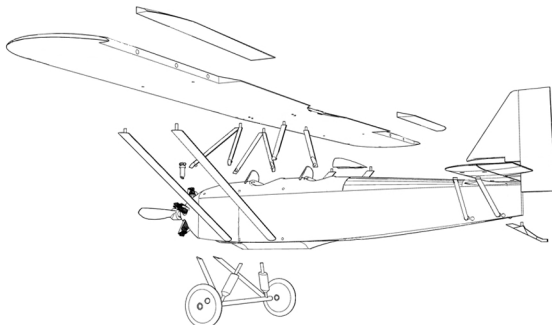
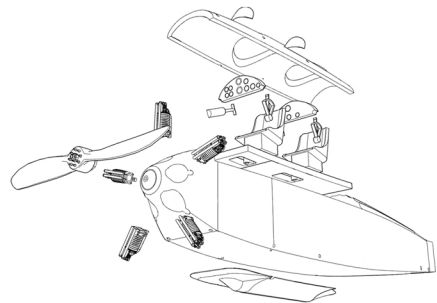
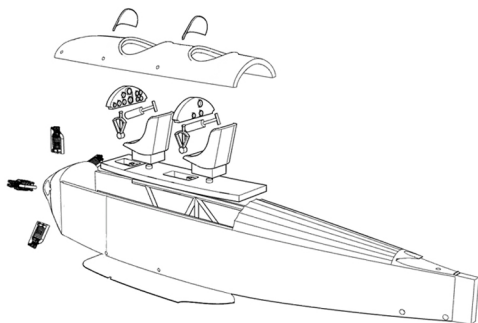

Decals: White images + complete drying + black images