



Revell

Authentic Kit

THE SCALE OF THIS MODEL IS
1/72 ACTUAL SIZE OR 1" = 6'

H-635 COPYRIGHT 1965 BY REVELL INC., VENICE, CALIF LITHO IN U.S.A.

POLIKARPOV I-16

While the major air forces of the world were still producing biplane fighters, Russia startled them by introducing the spritely little I-16. One of the world's first monoplane fighters, it also was one of the first fighters to feature retractable landing gear.

The I-16 first saw combat during the Spanish Civil War in 1936 and its extreme maneuverability earned it the nickname "Mosca" or Fly by its pilots and "Rata" or Rat by its opponents. The short, stubby design of the I-16 was the secret of its agility and it soon displayed the advantage of the monoplane fighter as it emerged victoriously from combat with slower biplanes.

As World War II engulfed the Russians, the little I-16 found itself outclassed by the German Bf 109's. Refinements to the basic aircraft did little to improve the performance in the face of the newer fighters but the I-16 proved quite effective in assaults on unescorted German bombers. Probably the most unique fighting tactic to emerge from the war was employed by I-16 pilots. The Russians would fly up to German bombers and slice their tails off with special steel-edged propellers.

Many I-16's were fitted with skis and flown from snow-covered airstrips during the Russo-Finnish War in 1939-40.

Although it was obsolete for most of the war, the barrel-like I-16 served valiantly for the major part of the conflict. The I-16, Type 24, reproduced by your Revell model, had a wingspan of 29 ft. 6 in. and length of 20 ft. 1 in. The nine cylinder air-cooled engine was manufactured by Shvetsov with a maximum rating of 1,000 hp. Top speed was 326 mph, service ceiling was 29,530 ft. The I-16 was armed with two 7.62 mm machine guns and two 20 mm cannons. These could be augmented by six underwing rockets.

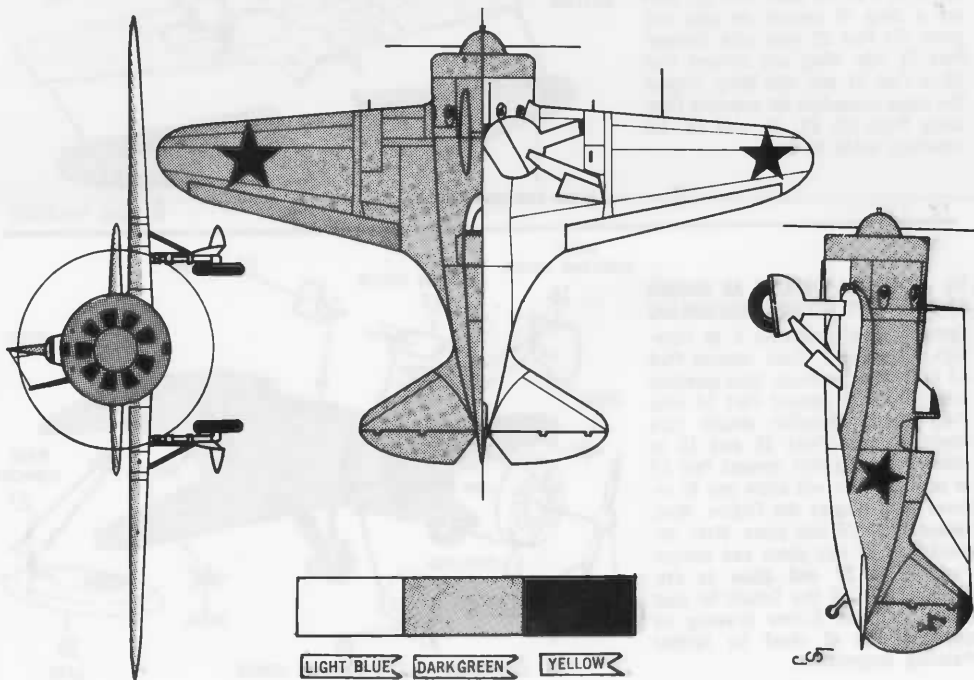

NOTE: Do not use too much Cement or it will soften plastic. Keep Cement away from your eyes, furniture and clothing. Use REVELL CEMENT for cementing, and REVELL PAINT SET COLORS for painting. Paint parts before cementing. Start with STEP 1 and FOLLOW NUMBERED STEPS.

I. PAINT ALL DETAILS AS SHOWN AND LET DRY BEFORE ASSEMBLING

Cement Part 1 onto 2, then cement Part 2 into 3. Apply cement to edges of Part 4 and assemble to Part 3, locating Pilot's Seat Properly. Now, cement Parts 8 and 9 into place as shown. Next, insert, DO NOT cement Part 10 into 11. Cement Part 11 to 12, being careful that no cement touches Part 10 or it will not turn. Finally cement Part 12 to Fuselage and set aside to dry.

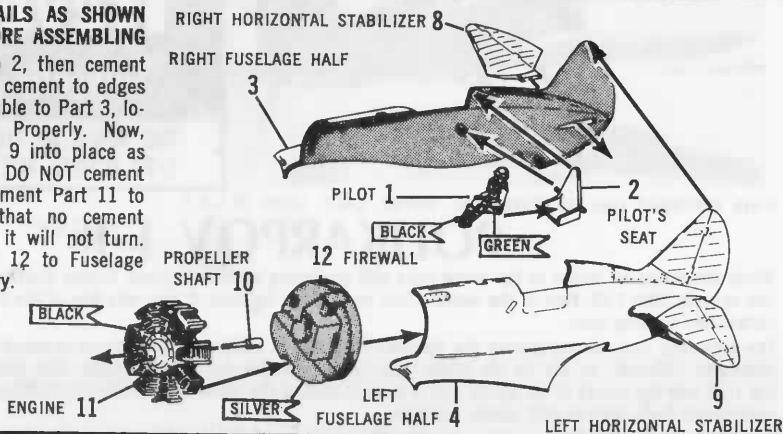

II. PAINT ALL DETAILS AS SHOWN AND LET DRY BEFORE ASSEMBLING

Cement Parts 6 and 7 to Part 5. If you wish to build your Model in a Flight Attitude, DO NOT use Parts 20 thru 25, but simply cement Parts 18 and 19 in a closed position on Wing. If you wish to build your Model in a Landing Attitude, slide DO NOT cement (1) Part 20 onto Part 21, then put a drop of cement on axle and press (1) Part 22 onto axle. Cement Part 21 into Wing and cement Part 24 to Part 21 and into Wing. Repeat the same procedure for opposite Gear using Parts 20, 22, 23, and 25. Set assembly aside to dry.

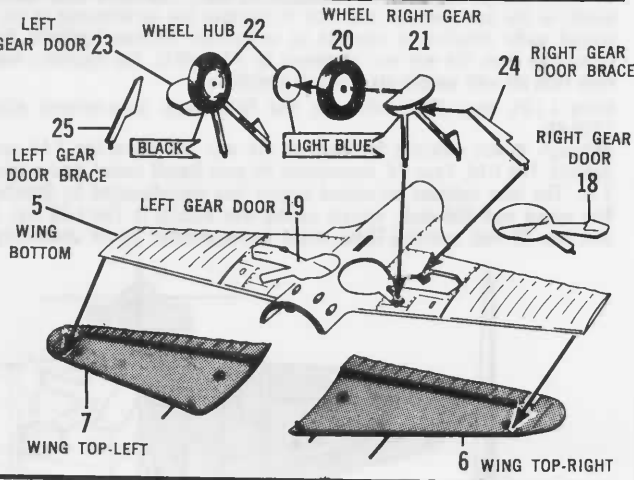

III. PAINT ALL DETAILS AS SHOWN AND LET DRY BEFORE ASSEMBLING

Cement Wing, Assembly 2 to Fuselage, Assembly 1. Next, cement Part 13 to front of Fuselage, then carefully press, DO NOT cement Part 14 onto Prop Shaft. Propeller should turn freely. Cement Parts 15 and 16 in place. Place DO NOT cement Part 17 in position, this will allow you to remove it to display the Engine. Now, cement Part 26 into place. Next, cement Part 27 into place and cement Part 28 to 27 and allow to dry. Finally apply all the Decals to your Model and see 3-View Drawing on opposite side of sheet for further Painting Suggestions.

