

35 K18



EXCLUSIVE EDITION

UPGRADE SET
FOR DRAGON
1/35 MODEL

GERMAN TANK DESTROYER
JAGDPANTHER

(Sd.Kfz. 173) - Ausf. G2

Late version

Niemiecki niszczyciel czołgów "Jagdpanther G2"- późna wersja

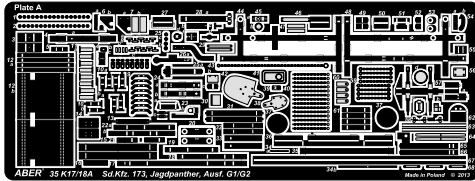
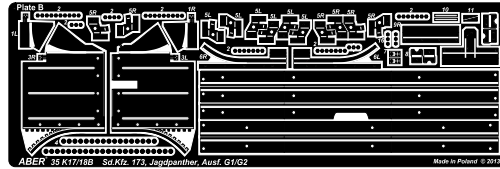
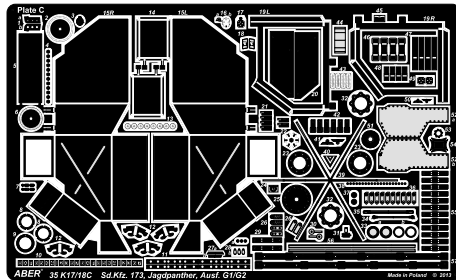
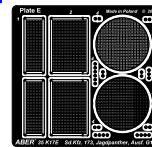
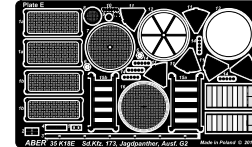
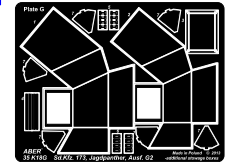
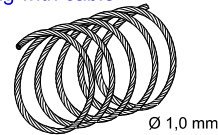
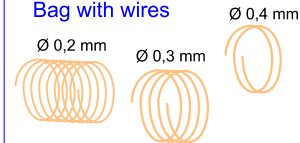
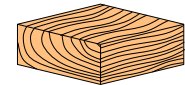
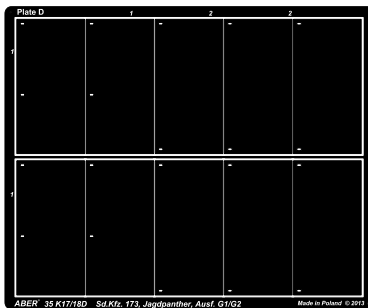
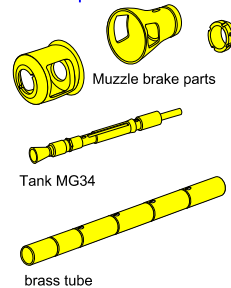
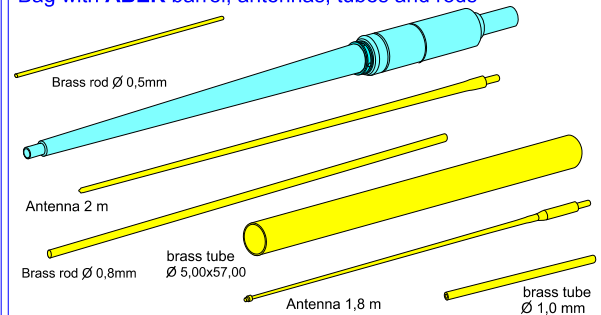
A**B****F****C****E****E****G****Bag with cable****Bag with wires****Bag with wood chock****D****Turned parts****Bag with ABER barrel, antennas, tubes and rods**

MOST IMPORTANT BIBLIGRAPHY:

- 1) Achtung Panzer No.4 - PANTHER, Jagdpanther & Brummbär by Mitsuru Bitoh - Dai Nippon Kaiga Co.,Ltd. ©1994
- 2) AFV Modeling Guide Vol.4 -Schwere Jagdpanzer - Geibusha Publishing ©2010
- 3) GROUND POWER No.007, 008, 189 - Delta Publishing Co.,Ltd. ©1995, ©2010
- 4) Militärfahrzeuge Band 9; Der Panzer-Kampfwagen Panther und Seine Abarten - Walter J. Spielberger - Motorbuch ©1994
- 5) Panzer Tracts No.9-3 -"Jagdpanther" Thomas L. Jentz & Hilary Louis Doyle
- 6) New Vanguard 22: PANTHER VARIANTS 1942-1945 - Osprey Military ©1997

Thank you for purchase our set **35 K18**.

Read carefully this instruction.

We advise that better method to join metal to metal parts is soldering.

Cement metal parts to plastic with good cyanoacryl or epoxy glue.

WARNING

Any unauthorized copying, producing and reproducing of ABER company products, or any part thereof, is strictly prohibited and any such action establishes liability for a civil action and may give rise to criminal prosecution.

OSTRZEŻENIE

Jakiegokolwiek kopiowanie, produkowanie i reprodukcja wyrobów firmy ABER bez zezwolenia, w całości lub części jest surowo zabronione. Powyższe działania powodują powstanie odpowiedzialności cywilnej oraz mogą spowodować wszczęcie postępowania karnego.

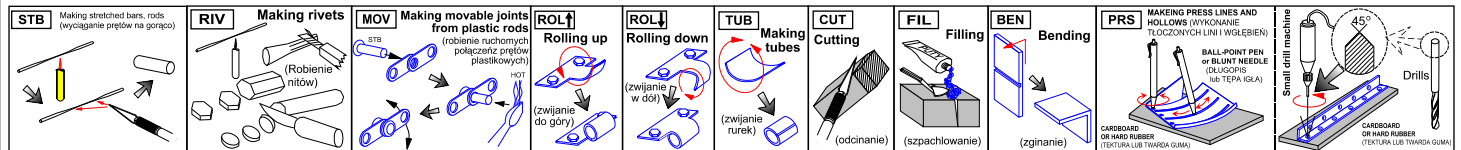

TOOLS RECOMMENDED

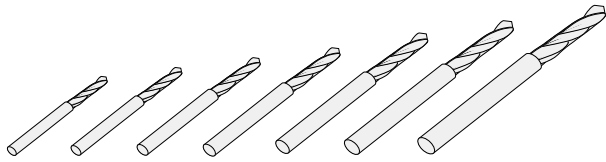

Drills from Ø 0,4 to 1,5 mm



Assortiment of cutting wheels and mills

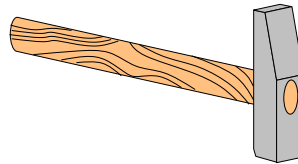

Light weight hammer

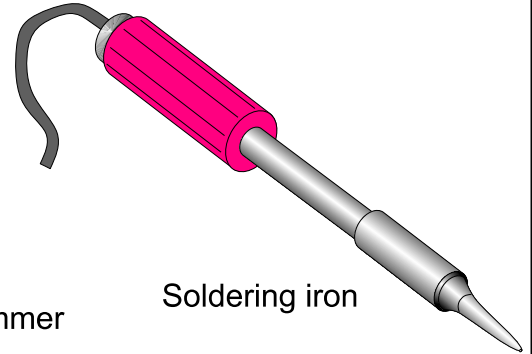

Soldering iron

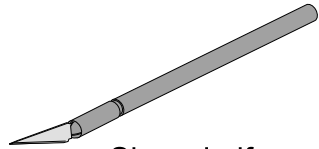

Sharp knife

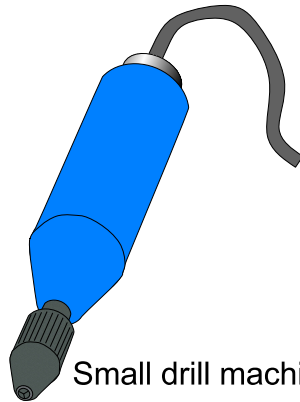

Small drill machine

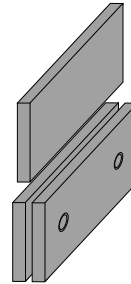

Bending tool
PG01 or PG02



Soldering flux



Solder

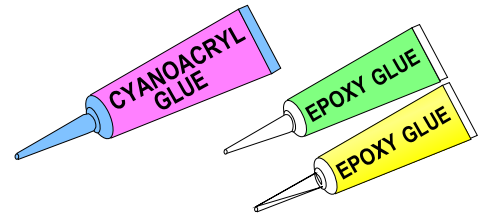

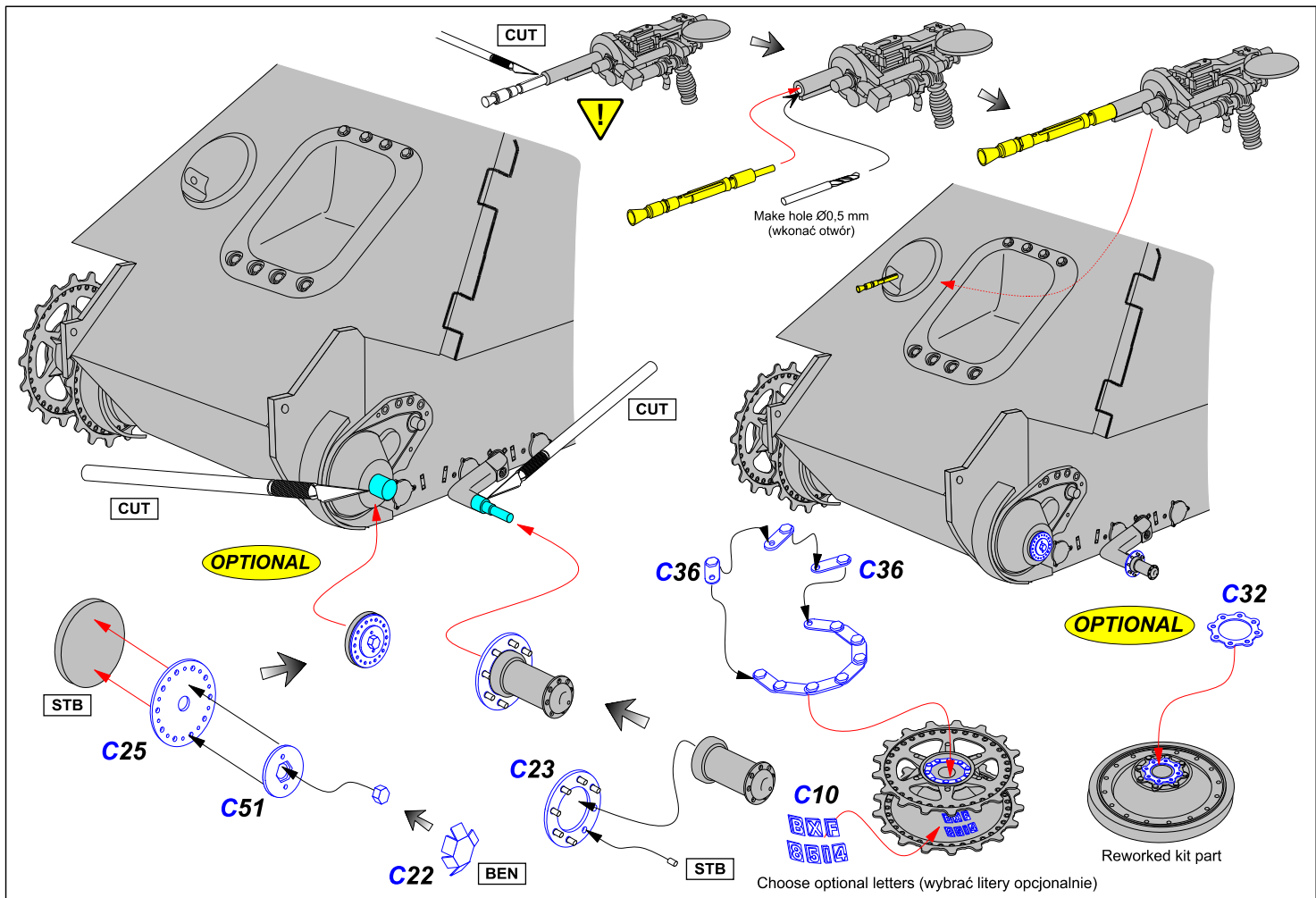

Lete model

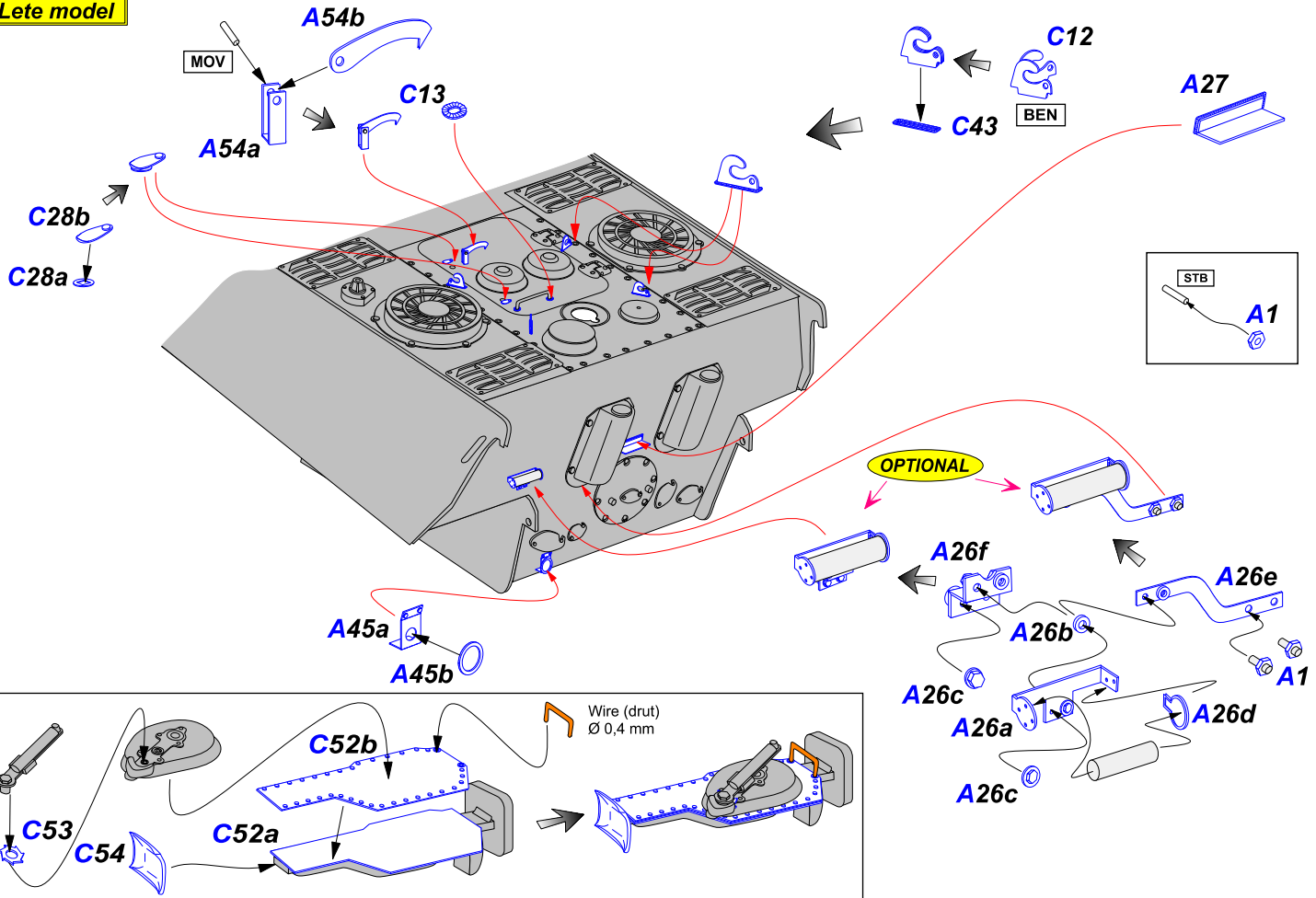

Lete model

Grilles from plate 35 K17E
Osłony siatkowe z płytki 35 K17E

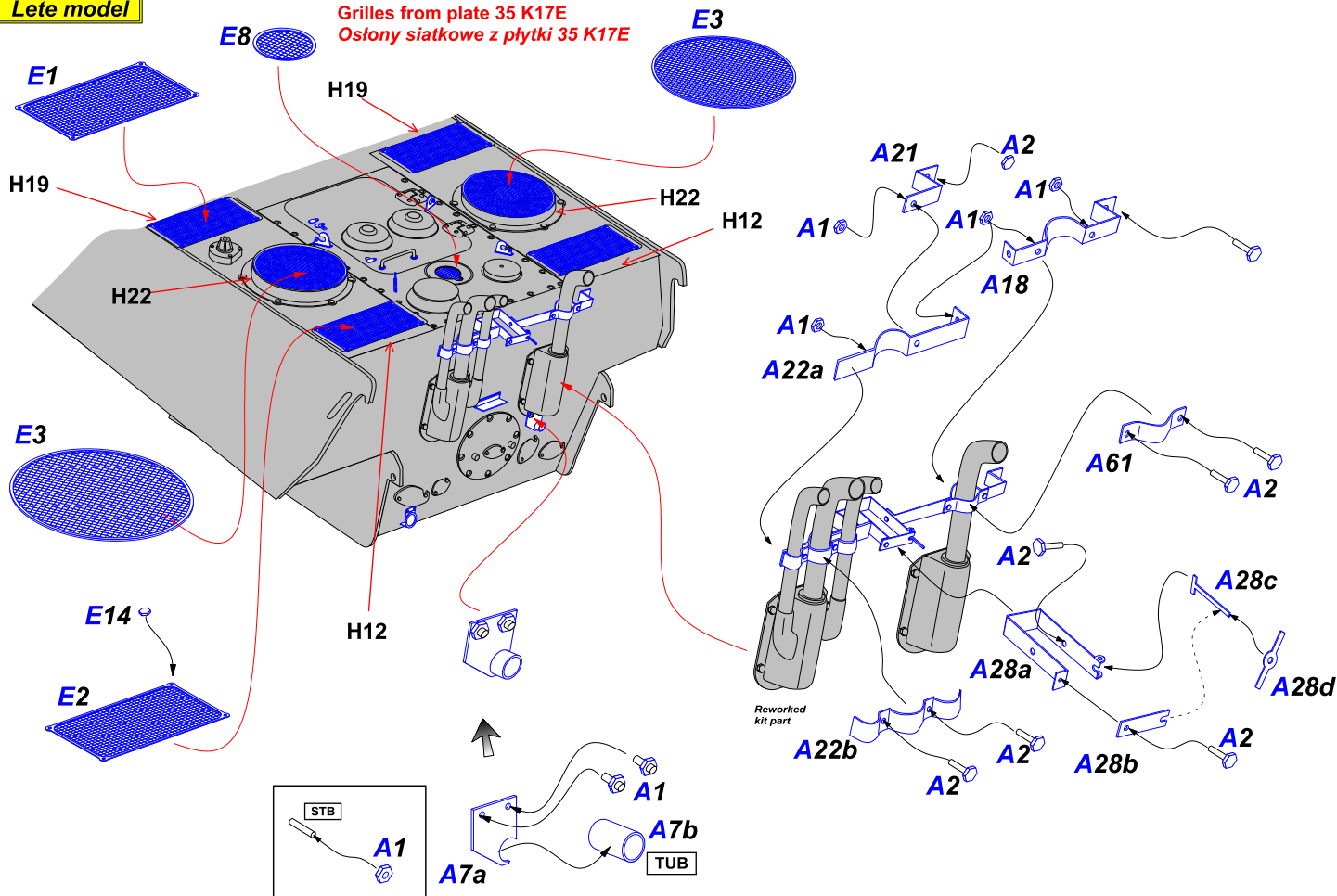

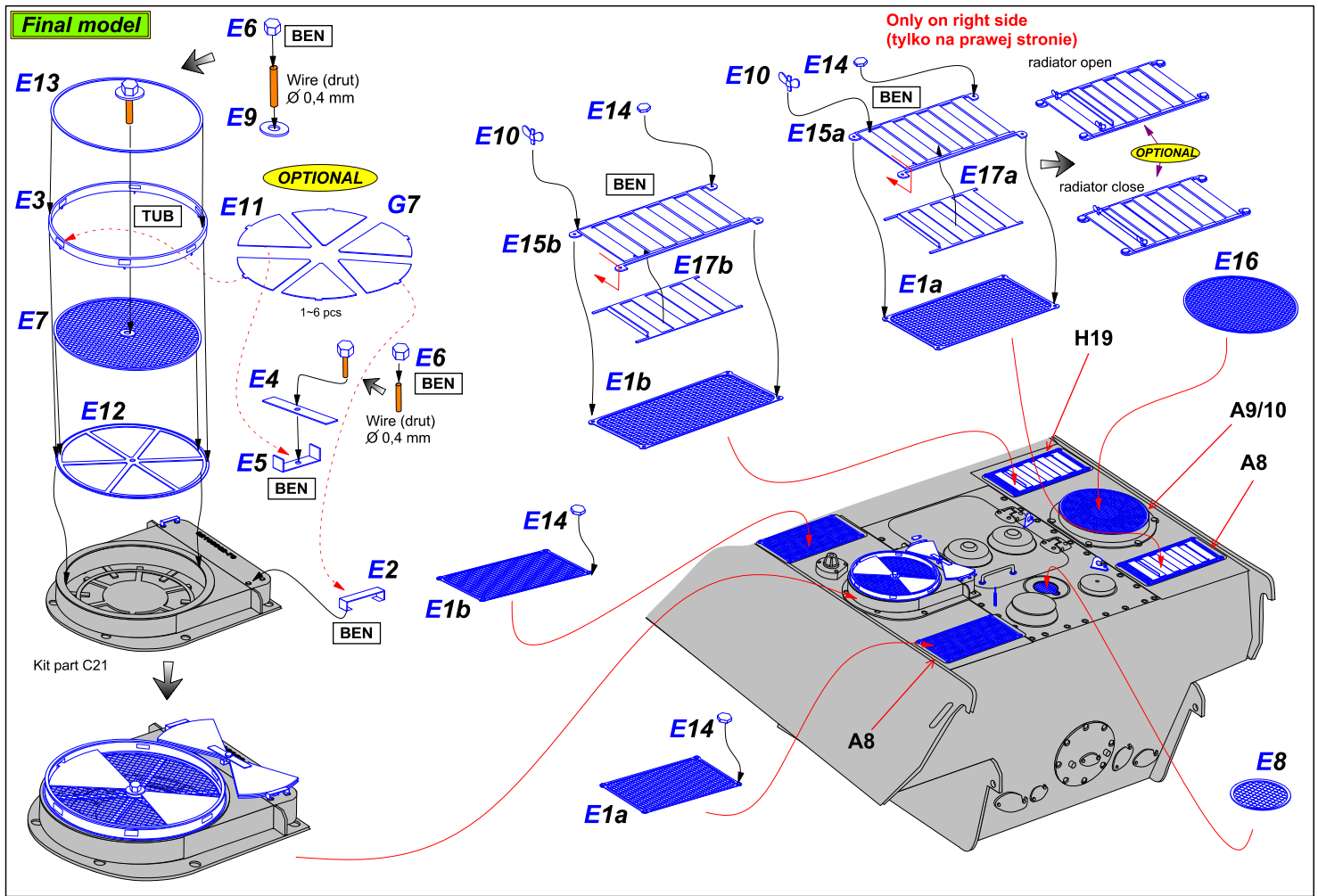

Final model

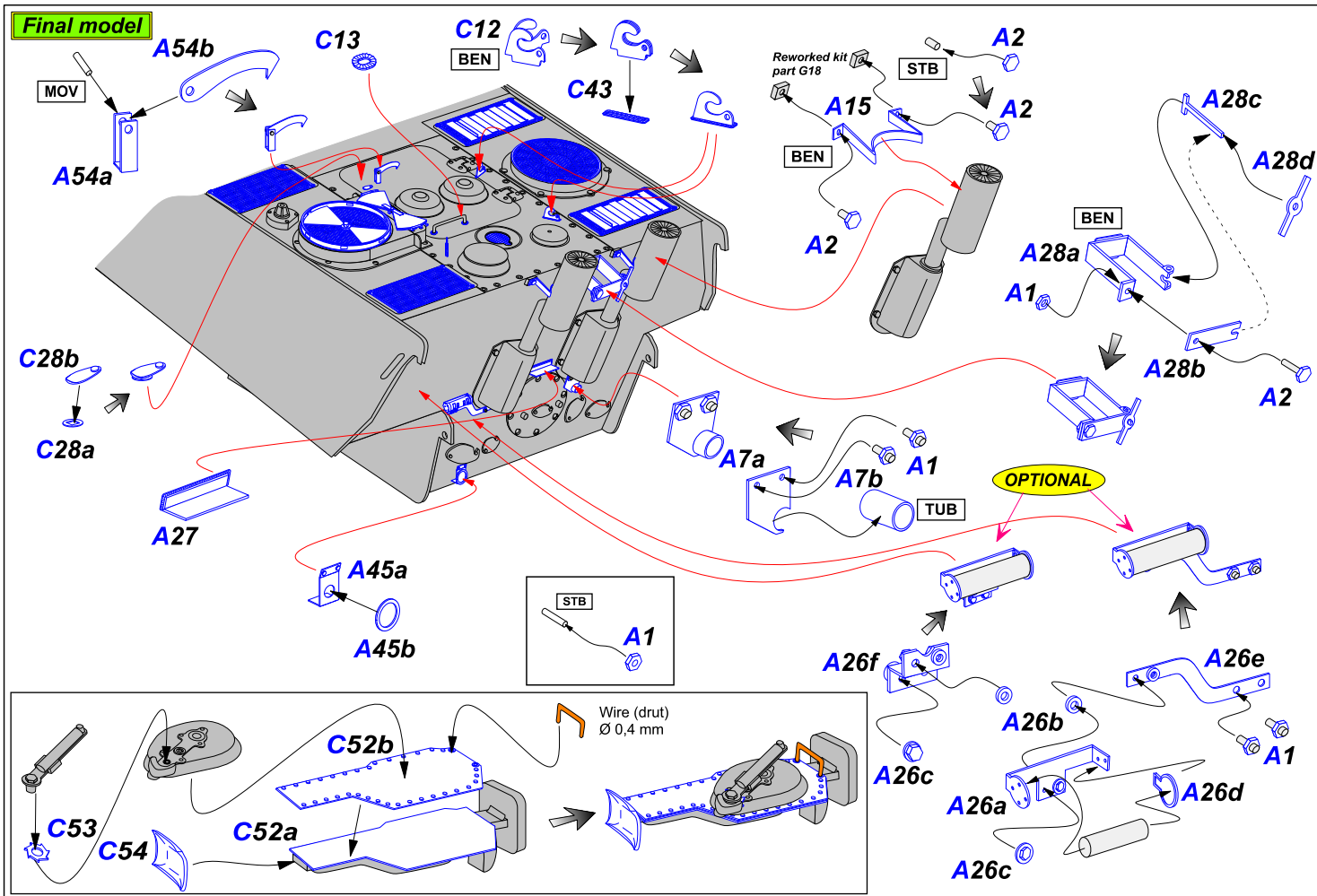

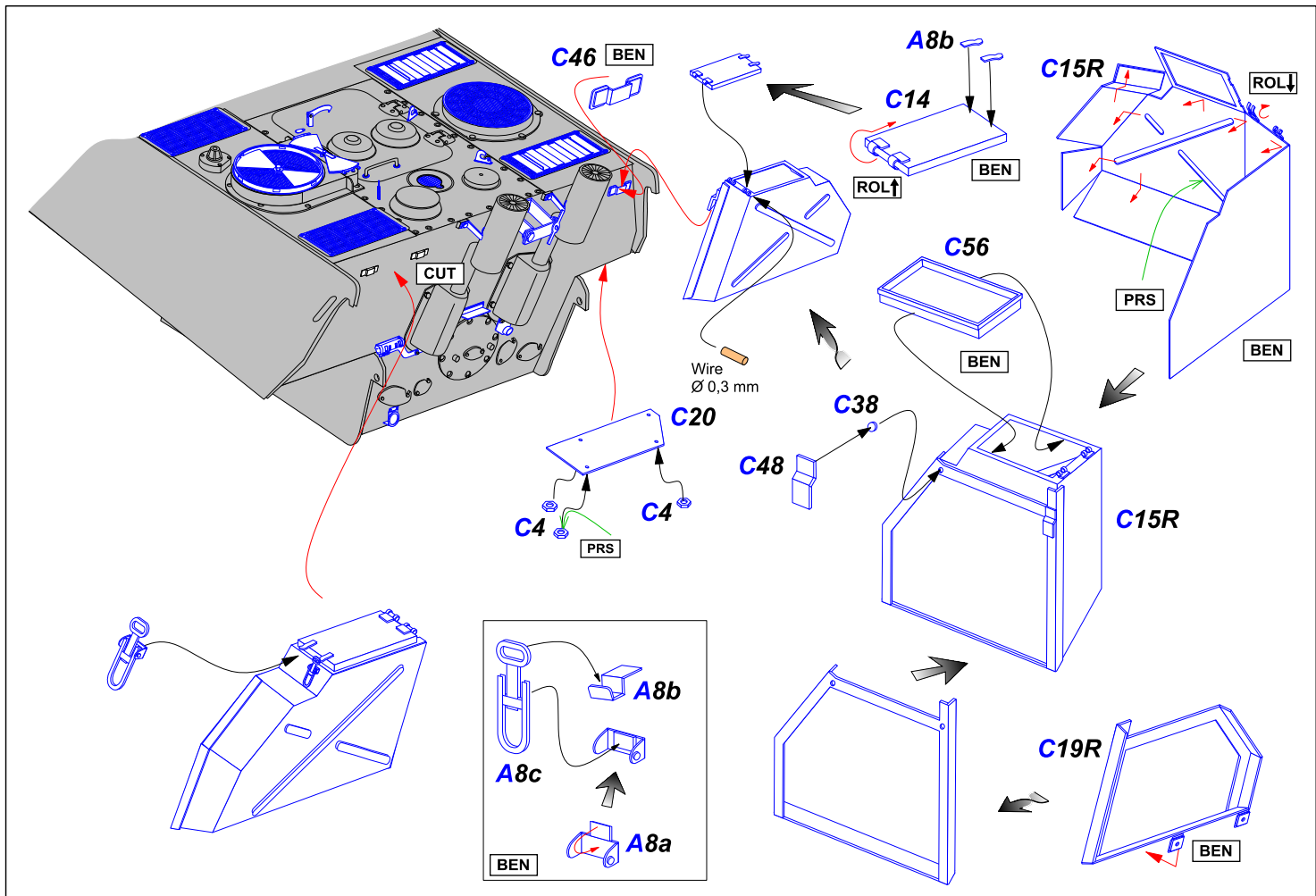

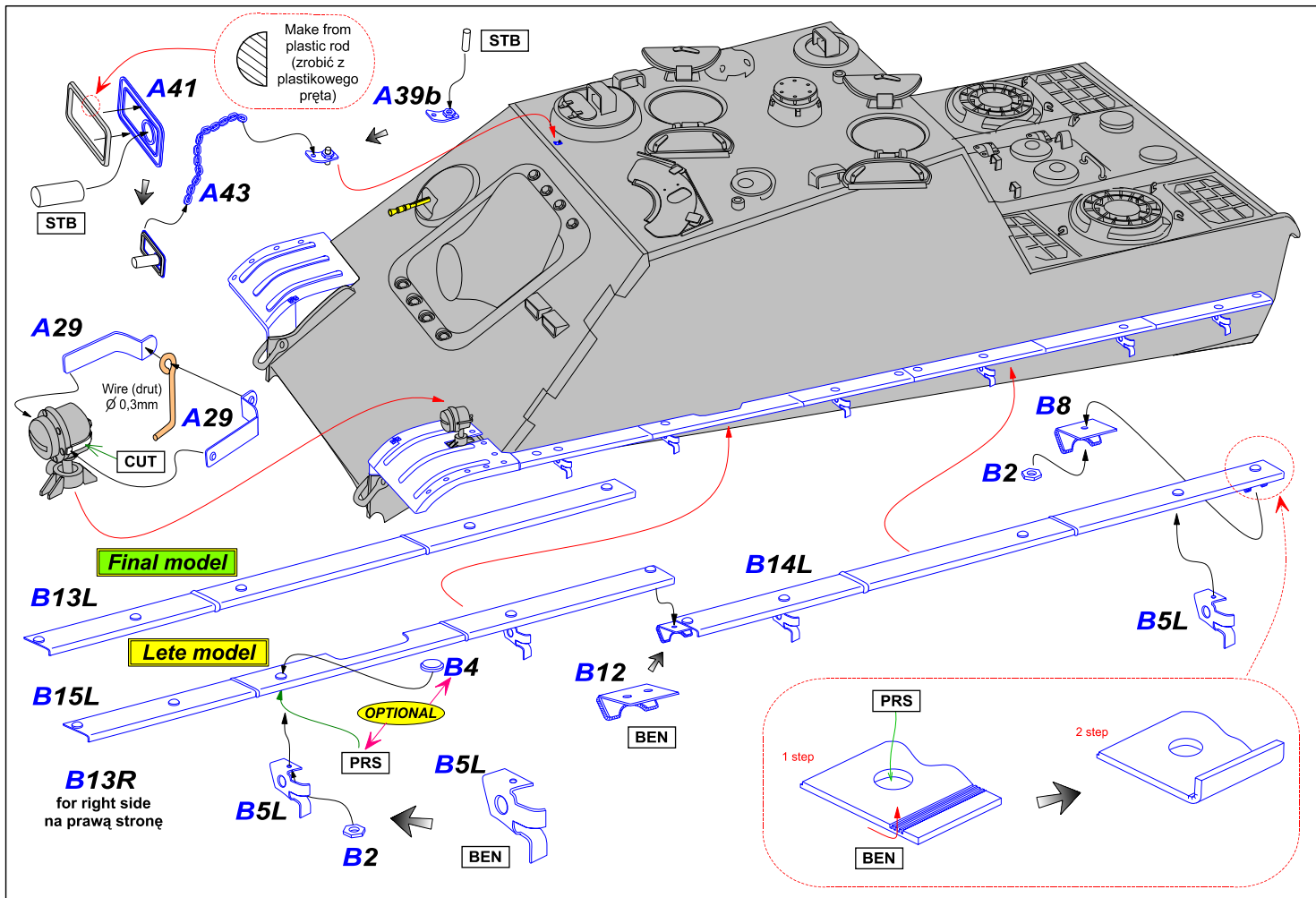

CLAMP A **A11b**

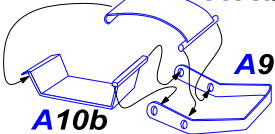

Lete model

CLAMP B **A11a**

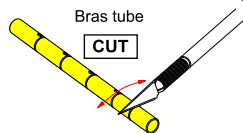
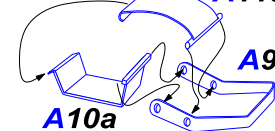

Bras tube

CUT

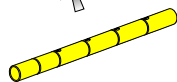

reworked kit part

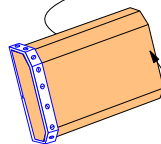

C11A36



BEN

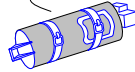

A50

BEN

Bras rod \varnothing 0,5 mm
(mosiężny pręt)

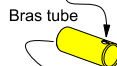

Bras tube

A59



A59



A53



A59

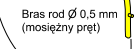

Bras rod \varnothing 0,5 mm
(mosiężny pręt)

Bras tube



A57c



A57b

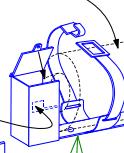

A57d



A57d

A57a

PRS

A49



BEN

BEN



A48



BEN

BEN



A51

BEN

A52



BEN

A35



BEN

BEN

B



B

Lete model

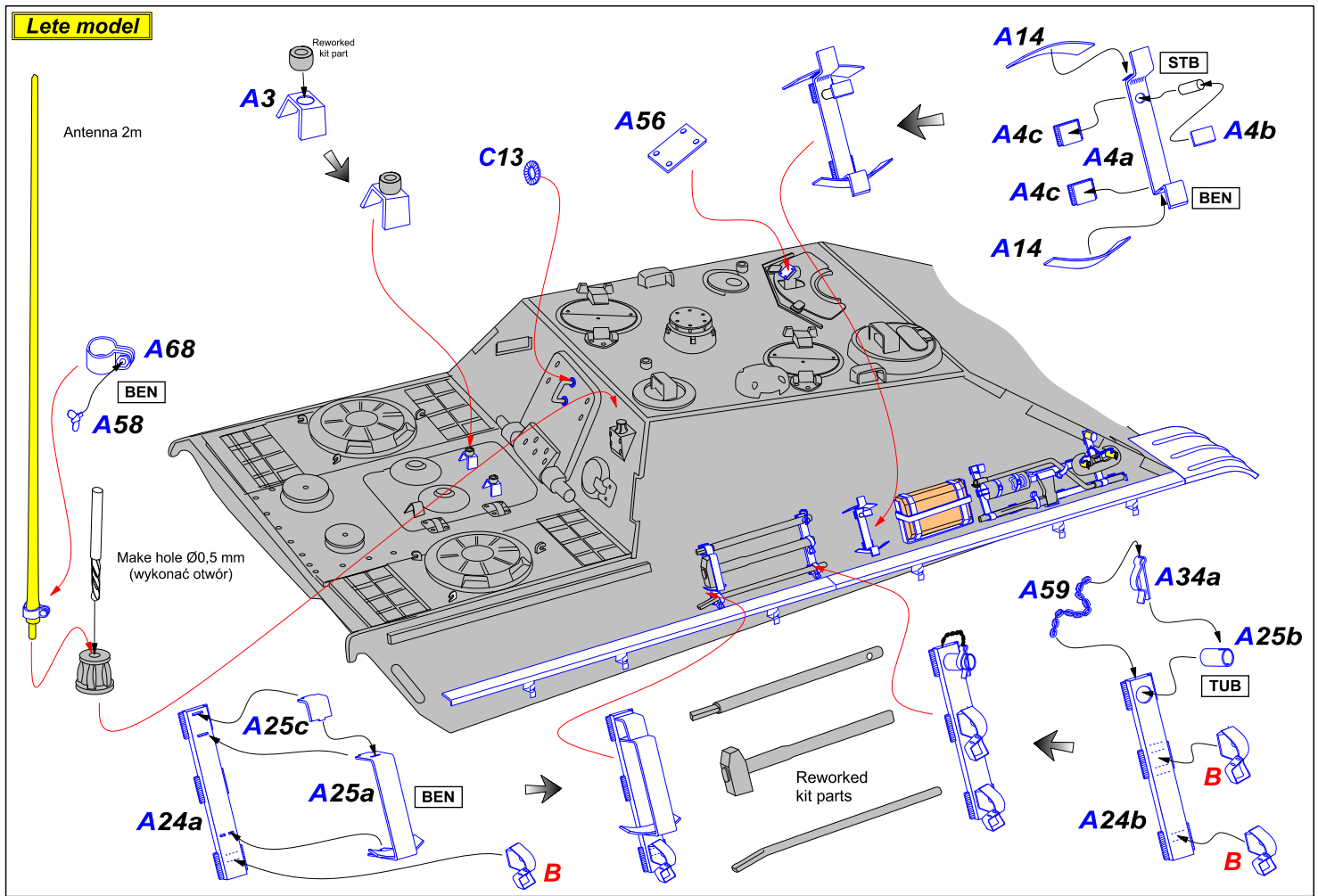

Lete model

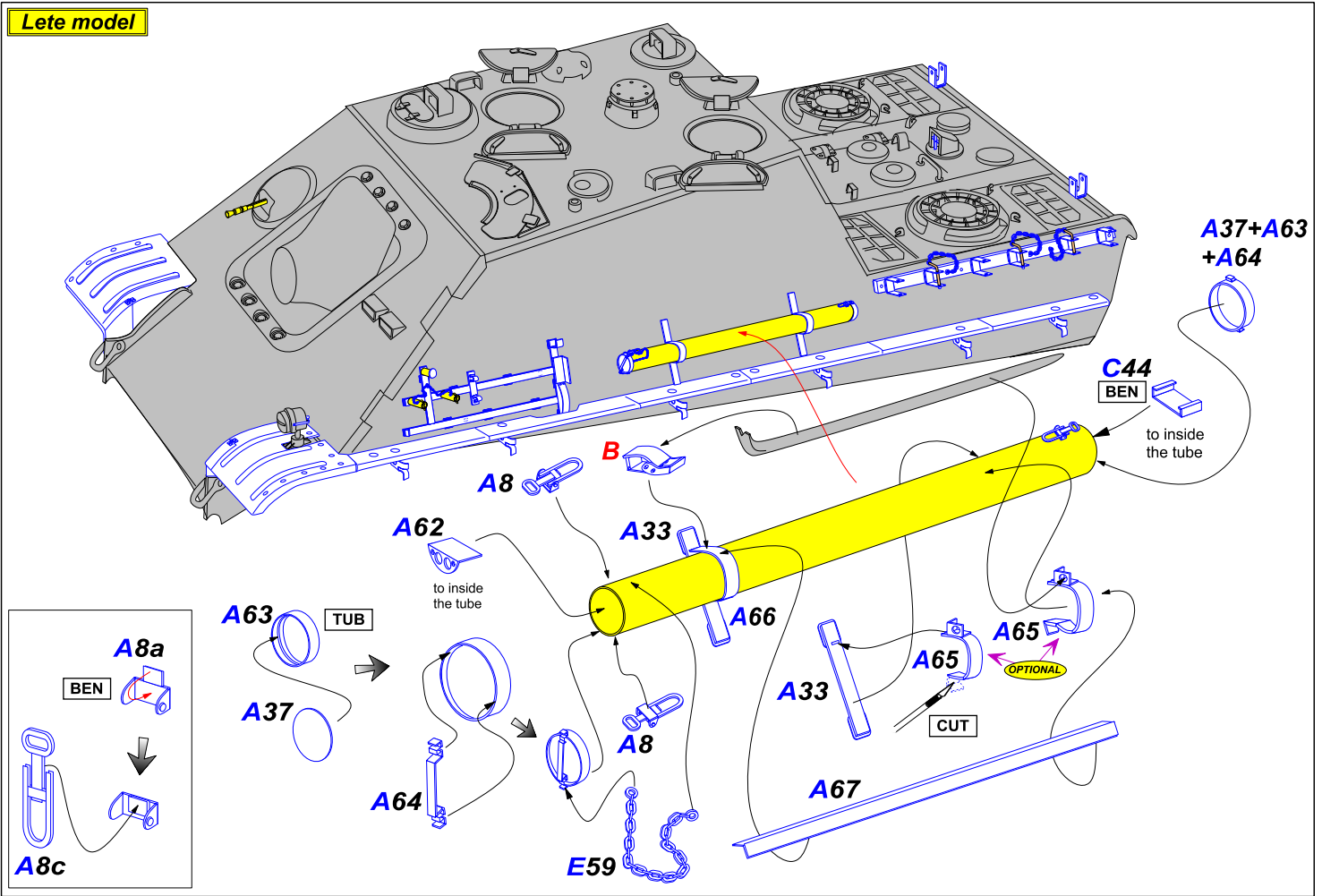

Final model

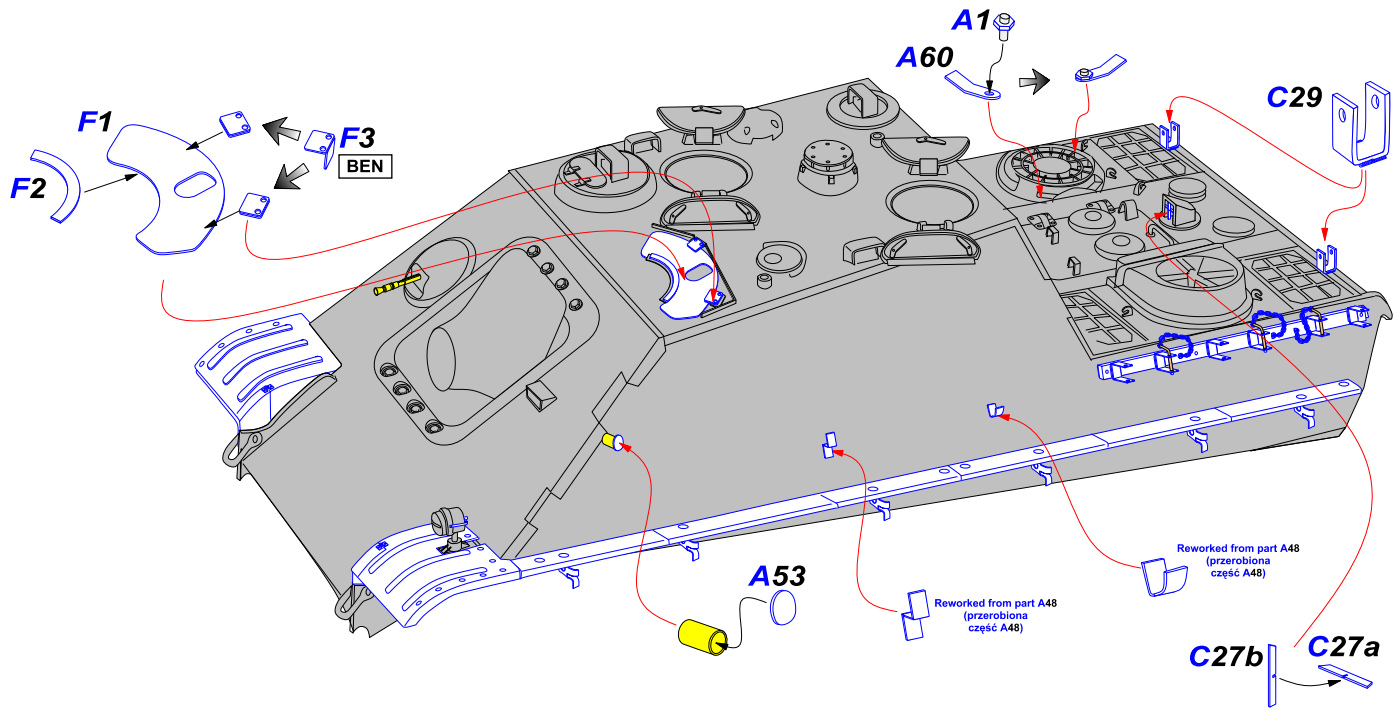

Final model

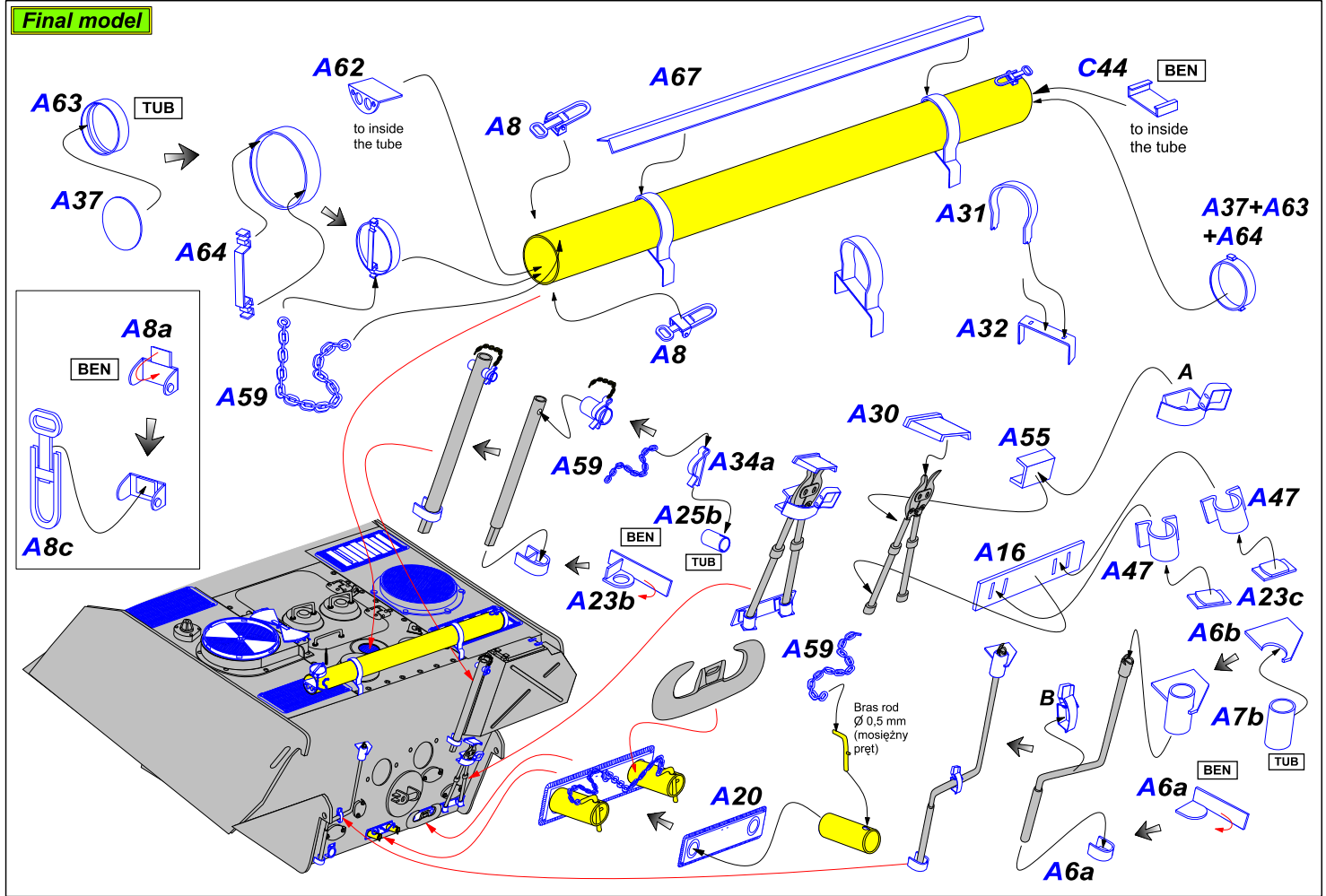

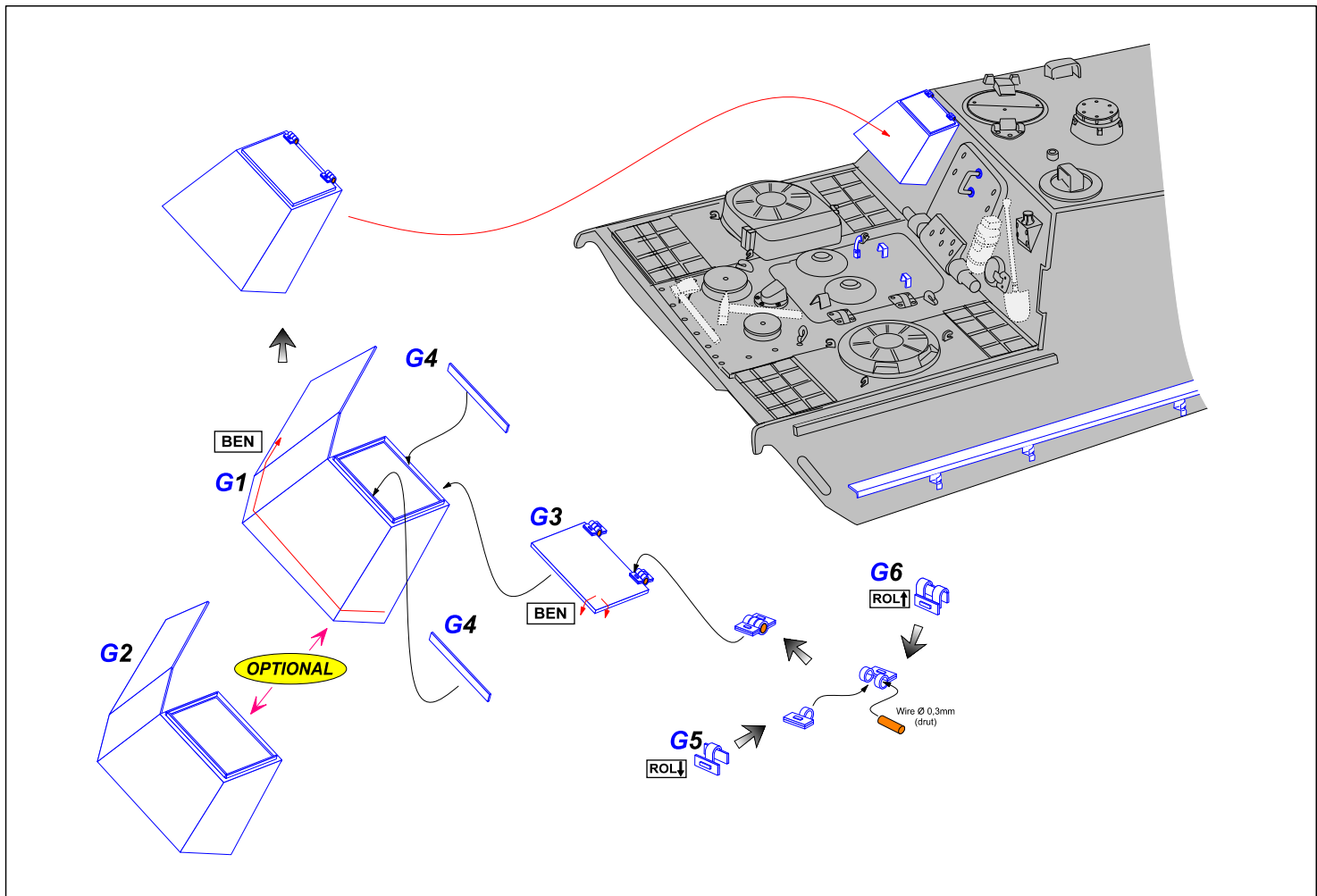

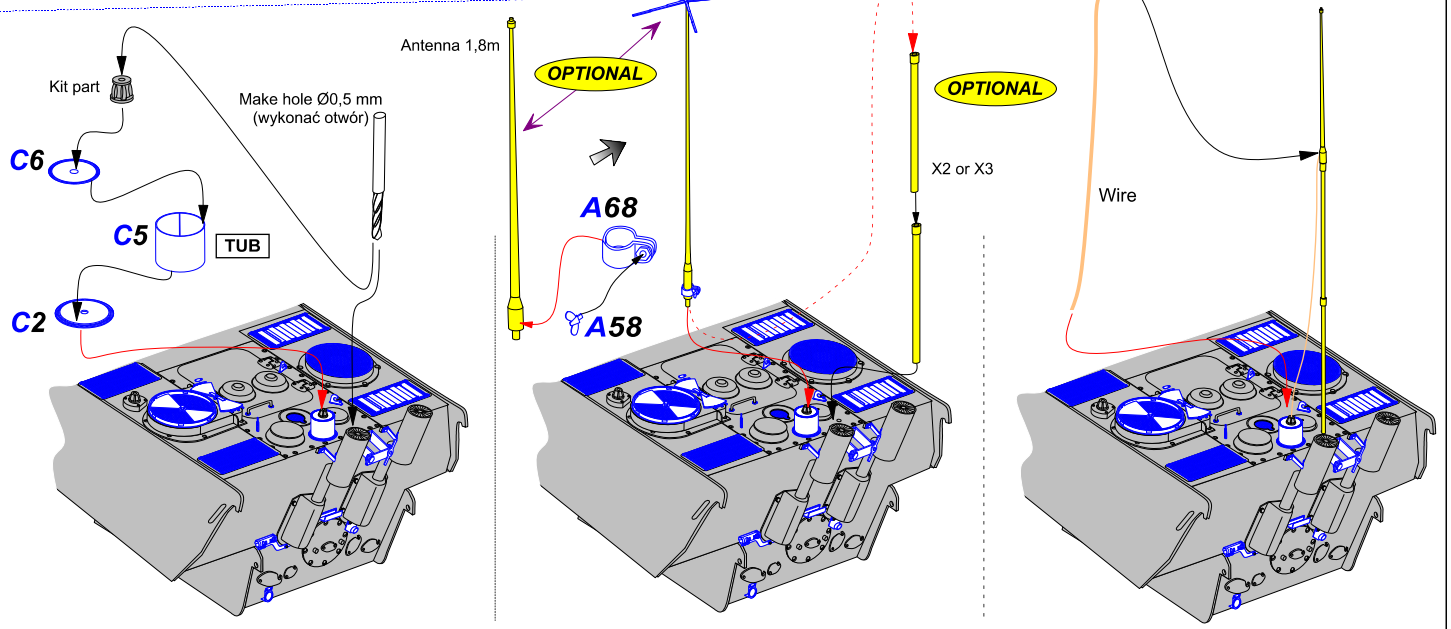
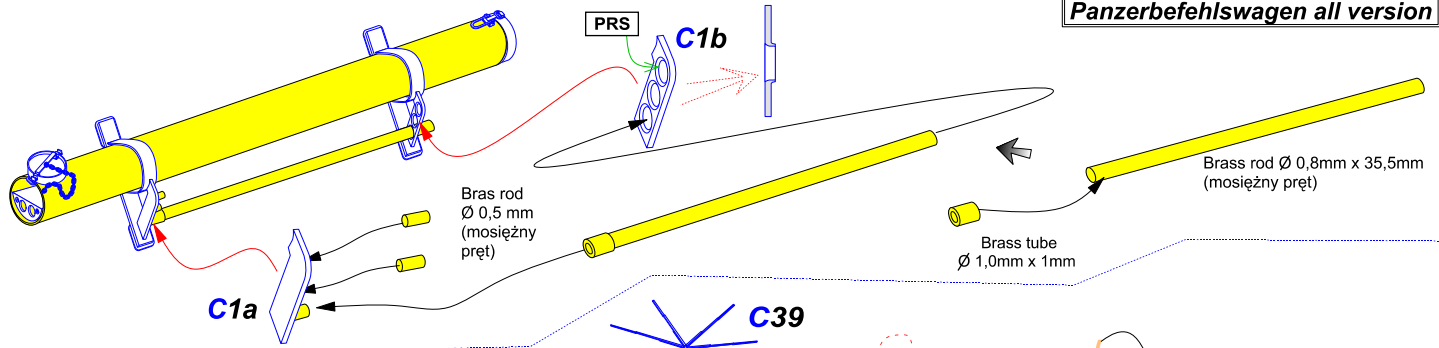

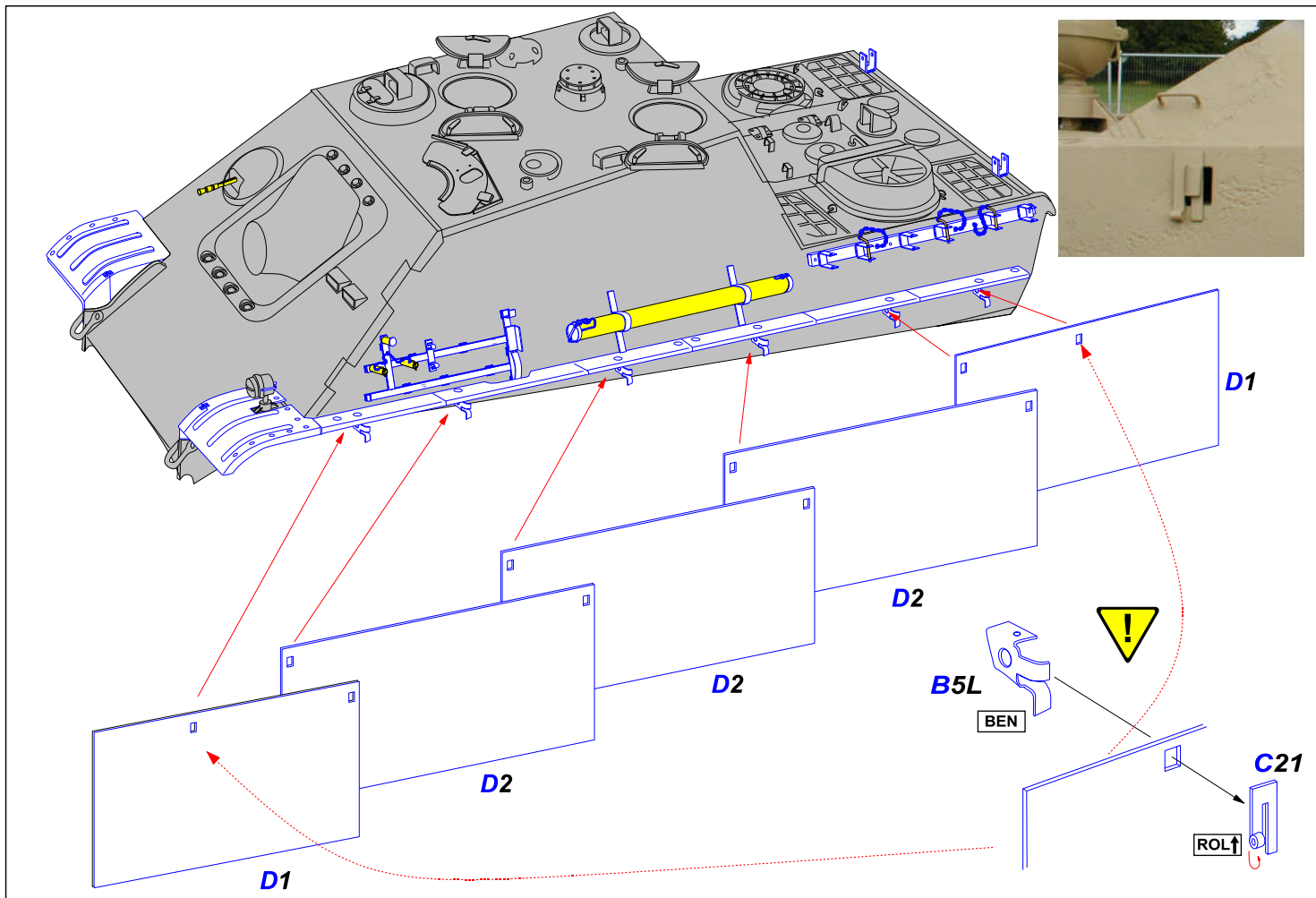

Here make incision
with hair saw
(tutaj zrobić nacięcie
pilką włosnicową)

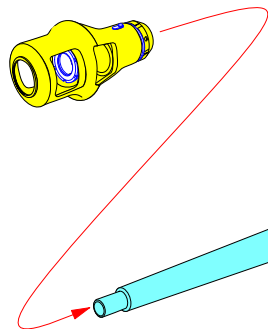
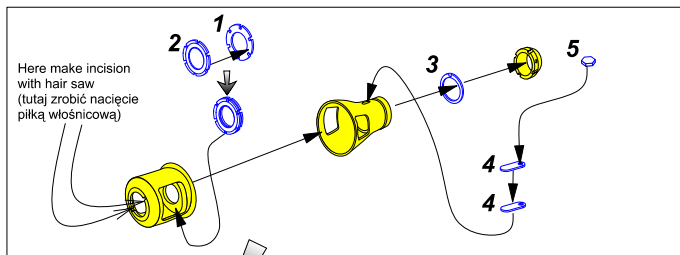

Kit part

Kit part



